



## ▶ PNOZ s30

# PILZ

THE SPIRIT OF SAFETY

Operating Manual-1001715-EN-22

- Safety relays



This document is the original document.

Where unavoidable, for reasons of readability, the masculine form has been selected when formulating this document. We do assure you that all persons are regarded without discrimination and on an equal basis.

All rights to this documentation are reserved by Pilz GmbH & Co. KG. Copies may be made for the user's internal purposes. Suggestions and comments for improving this documentation will be gratefully received.

Pilz®, PIT®, PMI®, PNOZ®, Primo®, PSEN®, PSS®, PVIS®, SafetyBUS p®, SafetyEYE®, SafetyNET p®, the spirit of safety® are registered and protected trademarks of Pilz GmbH & Co. KG in some countries.



SD means Secure Digital

<b>1</b>	<b>Introduction</b>	<b>7</b>
1.1	Validity of documentation	7
1.2	Using the documentation	7
1.3	Definition of symbols	7
1.4	Third-party manufacturer licence information	8
<b>2</b>	<b>Overview</b>	<b>9</b>
2.1	Unit structure	9
2.1.1	Range	9
2.1.2	Unit features	9
2.2	Front/side view	10
<b>3</b>	<b>Safety</b>	<b>12</b>
3.1	Intended use	12
3.2	Safety regulations	12
3.2.1	Safety assessment	12
3.2.2	Use of qualified personnel	13
3.2.3	Warranty and liability	13
3.2.4	Disposal	13
3.2.5	For your safety	13
<b>4</b>	<b>Security</b>	<b>14</b>
<b>5</b>	<b>Function description</b>	<b>15</b>
5.1	Introduction	15
5.2	Block diagram	15
5.3	Functions	16
5.3.1	Standstill	16
5.3.2	Speed	16
5.3.3	Speed range	17
5.3.4	Position	17
5.3.5	Direction	19
5.3.6	2 encoder diagnostics / broken shearpin monitoring	21
5.3.7	Hysteresis	21
5.3.8	Frequency filtering	22
5.3.9	Start types	24
5.3.10	Start-up delay	24
5.3.11	Synchronous start	24
5.3.12	Outputs	25
5.3.13	Switch delay	25
5.3.14	Feedback loops	26
5.3.15	Analogue output	26
5.3.16	Units	27
5.3.17	Timing diagram for speed monitoring	28
5.4	Speed configuration	29
5.4.1	Select Inputs	31
5.4.2	Switch functions	32
5.4.3	Special functions	34

5.4.4	Basic configuration .....	35
5.4.5	Chip card .....	37
5.5	Input device types .....	37
5.5.1	Proximity switch .....	37
5.5.2	Rotary encoders .....	38
5.5.2.1	Output signals .....	39
5.5.2.2	Adapter for incremental encoders .....	41
<b>6</b>	<b>Installation .....</b>	<b>42</b>
6.1	General installation guidelines .....	42
6.1.1	Dimensions .....	42
<b>7</b>	<b>Wiring .....</b>	<b>43</b>
7.1	General wiring guidelines .....	43
7.2	Pin assignment of RJ45 socket .....	43
7.3	Supply voltage .....	43
7.4	Connection of proximity switches .....	44
7.5	Connection of a rotary encoder .....	45
7.5.1	Connect rotary encoder to speed monitor .....	46
7.5.2	Connect rotary encoder with Z index to speed monitor .....	46
7.5.3	Connect rotary encoder to the speed monitor via an adapter .....	47
7.6	Connection of proximity switch and rotary encoder .....	48
7.7	Reset circuit .....	49
7.8	Feedback circuit .....	49
7.9	Select inputs .....	50
7.10	Semiconductor outputs .....	50
7.11	Analogue output .....	50
7.12	EMC-compliant wiring .....	51
<b>8</b>	<b>Display menu - Configuration .....</b>	<b>56</b>
8.1	Create configuration overview .....	56
8.2	Operate rotary knob .....	57
8.3	Configure Speed Monitor .....	57
8.4	Password protection .....	58
8.5	Use chip card .....	58
8.5.1	Insert chip card .....	59
8.5.2	Write data to chip card .....	60
8.5.3	Read data from chip card .....	60
8.5.4	Transfer device parameters .....	61
8.5.5	Duplicate chip card .....	61
8.5.6	Compatibility with older device versions .....	62
8.5.7	Special cases and problem solving .....	63
8.6	Save configuration with Software SmartCardCommander .....	64
8.7	Menu overview .....	66
8.7.1	Permanent display .....	66
8.7.2	Basic settings Ini pnp pnp .....	66
8.7.3	Basic settings for the rotary encoder .....	67
8.7.4	Settings .....	69

8.7.5	Advanced settings .....	77
8.7.6	Information .....	80
8.7.7	Restart .....	81
8.7.8	Menu messages .....	82
8.8	Example: Configure basic configuration 2 .....	85
<b>9</b>	<b>Create configuration in PNOZsigma Configurator .....</b>	<b>86</b>
9.1	Download project from the PNOZsigma Configurator to the PNOZ s30 .....	86
9.2	Transfer project from PNOZ s30 to the PNOZsigma Configurator .....	87
<b>10</b>	<b>Function test during commissioning .....</b>	<b>89</b>
<b>11</b>	<b>Operation and diagnostics .....</b>	<b>90</b>
11.1	LED indicators .....	90
11.2	Display .....	90
11.2.1	Error stack entries .....	90
11.2.2	Current error messages .....	91
11.2.3	Open circuit message .....	99
11.2.4	Frequency difference message on proximity switch .....	99
11.3	Function test of the relay outputs .....	100
<b>12</b>	<b>Technical details .....</b>	<b>101</b>
12.1	Safety characteristic data .....	107
12.2	Signal level of the encoders .....	108
<b>13</b>	<b>Supplementary data .....</b>	<b>109</b>
13.1	Service life graph of output relays .....	109
13.2	Permitted operating height .....	109
13.3	Categories .....	110
13.3.1	Safety level .....	110
13.3.2	Safety functions .....	111
13.3.3	Safety-related characteristic data for operation with non-safety-related rotary encoder without additional requirements .....	112
13.3.3.1	Permitted encoder types and output signals .....	112
13.3.3.2	Safety-related architecture .....	112
13.3.3.3	Achievable safety level .....	113
13.3.4	Safety-related characteristic data for operation with non-safety-related rotary encoder with mechanical fault exclusion .....	113
13.3.4.1	Permitted encoder types and output signals .....	113
13.3.4.2	Safety-related architecture .....	114
13.3.4.3	Achievable safety level .....	114
13.3.5	Safety-related characteristic data for operation with non-safety-related rotary encoder with diagnostics via the drive controller .....	114
13.3.5.1	Permitted encoder types and output signals .....	114
13.3.5.2	Requirements of the drive controller .....	115
13.3.5.3	Safety-related architecture .....	115
13.3.5.4	Achievable safety level .....	116
13.3.6	Safety-related characteristic data for operation with a safe rotary encoder .....	116

13.3.6.1	Permitted encoder types and output signals .....	116
13.3.6.2	Safety-related architecture .....	116
13.3.6.3	Achievable safety level.....	117
13.3.7	Safety-related characteristic data for operation with a safe rotary encoder with Z index .....	117
13.3.7.1	Permitted encoder types and output signals .....	117
13.3.7.2	Safety-related architecture .....	117
13.3.7.3	Achievable safety level.....	118
13.3.8	Safety-related characteristic data for operation with non-safety-related rotary encoder and proximity switch .....	118
13.3.8.1	Permitted encoder types and output signals .....	118
13.3.8.2	Safety-related architecture .....	119
13.3.8.3	Achievable safety level.....	119
13.3.9	Safety-related characteristic data for operation with 2 proximity switches .....	119
13.3.9.1	Permitted encoder types and output signals .....	119
13.3.9.2	Safety-related architecture .....	120
13.3.9.3	Achievable safety level.....	120
13.3.10	Safety characteristic data for operation with 2 proximity switches with reduced diagnostics ...	121
13.3.10.1	Permitted encoder types and output signals .....	121
13.3.10.2	Safety-related architecture .....	121
13.3.10.3	Achievable safety level.....	122
13.4	Examples .....	122
13.4.1	Connection of proximity switch.....	122
13.4.1.1	Features .....	122
13.4.1.2	Configuration overview.....	123
13.4.2	Incremental encoder connection .....	125
13.4.2.1	Features .....	125
13.4.2.2	Configuration overview.....	125
<b>14</b>	<b>Order reference .....</b>	<b>127</b>
14.1	Product.....	127
14.2	Accessories .....	127
<b>15</b>	<b>EC declaration of conformity .....</b>	<b>131</b>
<b>16</b>	<b>UKCA-Declaration of Conformity .....</b>	<b>132</b>

# 1 Introduction

## 1.1 Validity of documentation

This documentation is valid for the product PNOZ s30 from Version 3.2.

This operating manual explains the function and operation, describes the installation and provides guidelines on how to connect the product.

## 1.2 Using the documentation

This document is intended for instruction. Only install and commission the product if you have read and understood this document. The document should be retained for future reference.

## 1.3 Definition of symbols

Information that is particularly important is identified as follows:



### **DANGER!**

This warning must be heeded! It warns of a hazardous situation that poses an immediate threat of serious injury and death and indicates preventive measures that can be taken.



### **WARNING!**

This warning must be heeded! It warns of a hazardous situation that could lead to serious injury and death and indicates preventive measures that can be taken.



### **CAUTION!**

This refers to a hazard that can lead to a less serious or minor injury plus material damage, and also provides information on preventive measures that can be taken.



### **NOTICE**

This describes a situation in which the product or devices could be damaged and also provides information on preventive measures that can be taken. It also highlights areas within the text that are of particular importance.



**INFORMATION**

This gives advice on applications and provides information on special features.

## 1.4 **Third-party manufacturer licence information**

This product includes Open Source software with various licenses.

Further information is available in the document "Third-party manufacturer license information PNOZ s30" (document number 1006628) at [www.pilz.com](http://www.pilz.com).



## 2 Overview

### 2.1 Unit structure

#### 2.1.1 Range

Scope of delivery:

- ▶ Speed monitor PNOZ s30
- ▶ Terminator
- ▶ Connection terminals
- ▶ Chip card
- ▶ Chip card holder

#### 2.1.2 Unit features

Application of the product PNOZ s30:

Speed monitor for safe monitoring of standstill, speed, speed range, position and direction.

The product has the following features:

- ▶ Measured value recorded by
  - Incremental encoder
  - Proximity switch
- ▶ Measured variables
  - Standstill
  - Speed
  - Speed range
  - Position
  - Direction
  - Analogue voltage (track S)
- ▶ Positive-guided relay outputs
  - 2 safety contacts (NO)
  - 2 auxiliary contacts (NC)
- ▶ Semiconductor outputs
  - 4 auxiliary outputs, one output configurable as an analogue output
- ▶ Expansion interface for 2 more safe relay outputs that be controlled separately
- ▶ Can be configured via the display on the speed monitor
- ▶ Configuration is stored on a chip card
- ▶ Display
  - Current frequencies
  - Current position
  - Warning and error messages
- ▶ Status and fault LEDs

- ▶ Encoder connection technology:  
RJ45 socket

## 2.2 Front/side view

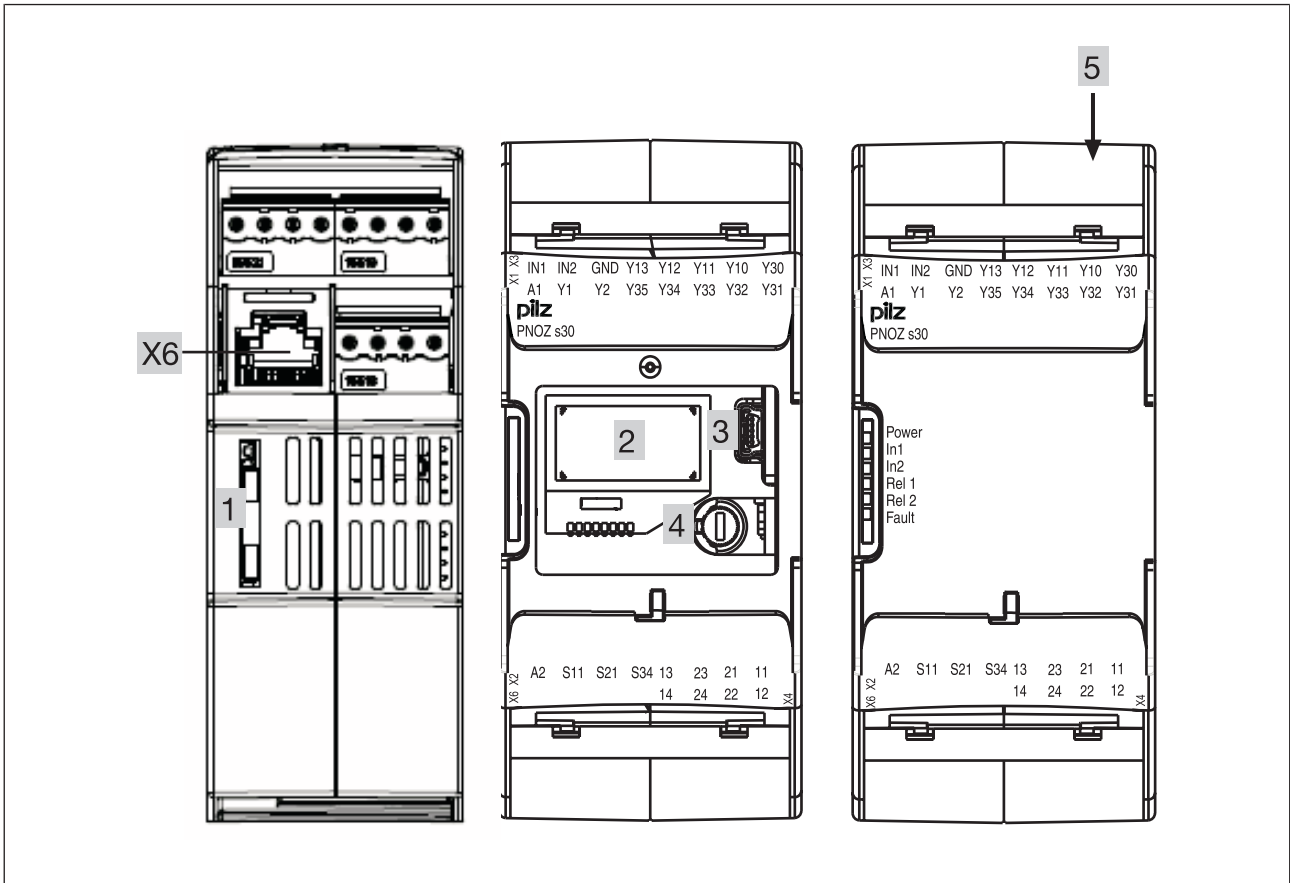

Fig.: Left: Side view, centre: Front view without cover, right: Front view with cover

Legend:

- ▶ A1, A2:  
Supply connections
- ▶ In1, In2, GND:  
Proximity switch 1 - In1 (track A) and 2 - In2 (track B) and GND
- ▶ Y10 ... Y13:  
Select inputs (SEL1, SEL2, SEL4, SEL8)
- ▶ 13-14 and 23-24:  
Relay outputs REL 1 and REL 2 (safety contacts)
- ▶ 11-12 and 21-22:  
Relay outputs REL 1 and REL 2 (auxiliary contacts)
- ▶ Y32 ... Y34: Semiconductor outputs OUT 1 ...- OUT 3 (auxiliary outputs)
- ▶ Y35: Semiconductor output OUT 4 (auxiliary output or analogue outputs)
- ▶ S11: +24 V / 30 mA (supply for S34, Y1 and Y2)
- ▶ S21: 0 V (GND for S11, S34, Y1 and Y2)
- ▶ S34: Start input

- ▶ Y1, Y2:
  - Y1: Feedback input for Rel. 1
  - Y2: Feedback input for Rel. 2
- ▶ Y30: 0 V ext (GND for select input and semiconductor outputs)
- ▶ Y31: 24 V ext (supply for semiconductor outputs)
- ▶ X6: RJ45 socket for connecting the encoder (tracks A, /A, B, /B, Z, /Z, S and GND). Proximity switches can be connected via RJ45 socket or connection terminals.
- ▶ 1: Chip card
- ▶ 2: Display
- ▶ 3: USB connection
- ▶ 4: Rotary knob
- ▶ 5: Expansion interface for 2 more external relay outputs
- ▶ LEDs:
  - Power
  - In1
  - In2
  - Rel 1
  - Rel 2
  - Fault

## 3 Safety

### 3.1 Intended use

The speed monitor monitors standstill, speed, speed range, position and direction in accordance with EN ISO 13849-1 up to PL e and EN IEC 62061 up to SIL CL 3.

The safety controller should be installed in a protected environment that meets at least the requirements of pollution degree 2. Example: Protected inside space or control cabinet with protection type IP54 and appropriate air conditioning.



#### **WARNING!**

Users must take appropriate measures to detect or exclude errors (e.g. slippage or broken shearpin) which cause the frequency of the encoder signal to no longer be proportional to the monitored speed.

Appropriate measures are:

- Using the monitored encoder to also control the drive
- Mechanical solutions
- Z-frequency monitoring with an additional proximity switch (Ini pnp) on the same axis



#### **NOTICE**

##### **EMC-compliant electrical installation**

The product is designed for use in an industrial environment. The product may cause interference if installed in other environments. If installed in other environments, measures should be taken to comply with the applicable standards and directives for the respective installation site with regard to interference.

### 3.2 Safety regulations

#### 3.2.1 Safety assessment

Before using a device, a safety assessment in accordance with the Machinery Directive is required.

The product as an individual component fulfils the functional safety requirements in accordance with EN ISO 13849 and EN IEC 62061. However, this does not guarantee the functional safety of the overall plant/machine. To achieve the relevant safety level of the overall plant/machine's required safety functions, each safety function needs to be considered separately.

### 3.2.2 Use of qualified personnel

The products may only be assembled, installed, programmed, commissioned, operated, maintained and decommissioned by persons who are competent to do so.

A competent person is a qualified and knowledgeable person who, because of their training, experience and current professional activity, has the specialist knowledge required. In order to inspect, assess and handle products, devices, systems, plant and machinery, this person must be familiar with the state of the art and the applicable national, European and international laws, directives and standards.

It is the company's responsibility only to employ personnel who

- ▶ Are familiar with the basic regulations concerning health and safety / accident prevention,
- ▶ Have read and understood the information provided in the section entitled Safety
- ▶ Have a good knowledge of the generic and specialist standards applicable to the specific application.

### 3.2.3 Warranty and liability

All claims to warranty and liability will be rendered invalid if

- ▶ The product was used contrary to the purpose for which it is intended,
- ▶ Damage can be attributed to not having followed the guidelines in the manual,
- ▶ Operating personnel are not suitably qualified,
- ▶ Any type of modification has been made (e.g. exchanging components on the PCB boards, soldering work etc.).

### 3.2.4 Disposal

- ▶ In safety-related applications, please comply with the mission time  $T_M$  in the safety-related characteristic data.
- ▶ When decommissioning, please comply with local regulations regarding the disposal of electronic devices (e.g. Electrical and Electronic Equipment Act).

### 3.2.5 For your safety

- ▶ The device is designed exclusively for use in an industrial environment. It is not suitable for use in a domestic environment, as this can lead to interference.
- ▶ The guarantee is rendered invalid if the housing is opened or unauthorised modifications are carried out.
- ▶ Adequate protection circuit must be provided on all output contacts with capacitive and inductive loads.

## 4 Security

- ▶ The product is not protected from physical manipulation or from reading of memory contents during physical access. Use appropriate measures to ensure that there is no physical access by unauthorised persons. You should also use security seals so that you can detect any manipulation of the product or interfaces. Installation inside a lockable control cabinet is recommended as a minimum measure.
- ▶ To protect against unauthorised access, no cable may be plugged into the USB connection during normal operation.
- ▶ The configuration computer that accesses the product has to be protected from attacks by a firewall or other suitable measures. We recommend that a virus scanner is used on this configuration computer and updated regularly.

## 5 Function description

### 5.1 Introduction

Proximity switches or encoders record measured values, which are evaluated in the speed monitor PNOZ s30. Up to 9 monitoring functions can be configured (F1 ... F9) which are run at a time.

Via the Select inputs, up to 16 different parameter sets (P0 ... P15) of the monitoring function can be chosen, e.g. to monitor various operating modes.

Configuration of the monitoring functions is menu-driven, using a rotary knob. The outputs switch depending on the configuration.

An interface is available to connect a contact expansion module PNOZsigma, enabling the number of outputs to be expanded.

The relay meets the following safety requirements:

- ▶ The circuit is redundant with built-in self-monitoring.
- ▶ The safety device remains effective in the case of a component failure.

### 5.2 Block diagram

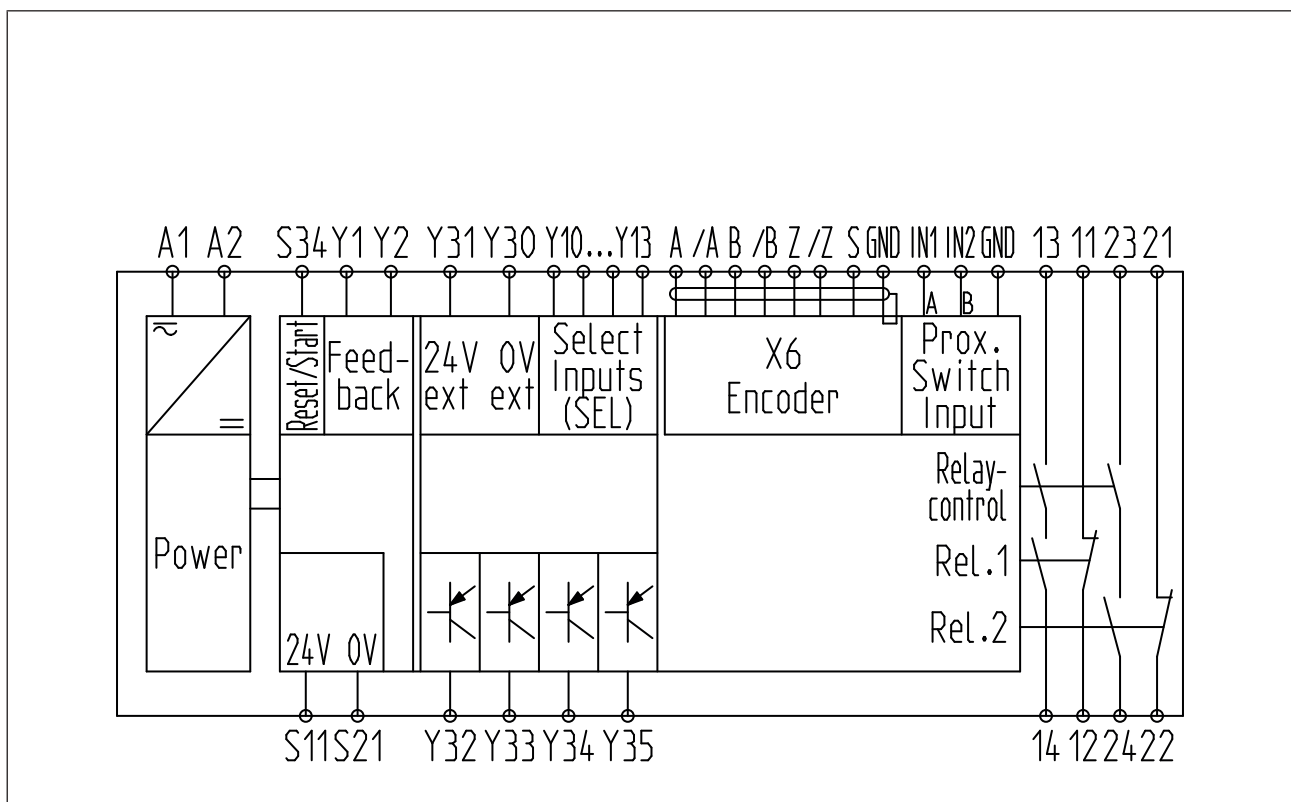



#### **NOTICE**

The individual blocks are galvanically isolated from each other:

- Supply voltage: A1, A2
- Encoder and initiator inputs: GND, In1, In2, RJ45 socket and shield
- Start and feedback circuits: S21, S11, S34, Y1, Y2
- Semiconductor outputs and select inputs: Y30, Y31, Y32, Y33, Y34, Y35, Y10, Y11, Y12, Y13
- Relay output 13, 14
- Relay output 11, 12
- Relay output 23, 24
- Relay output 21, 22

If possible, the connections for the various earth potentials (GND, S21, Y30 und A2) should not be connected on the PNOZ s30 but should be connected directly to the GNDs on the connected units, otherwise noise susceptibility may be increased significantly (conductor loops are not permitted).

## **5.3 Functions**

The following monitoring functions can be configured:

### **5.3.1 Standstill**

With standstill monitoring, the output is switched on when the value falls below the stated standstill value; if the standstill value is exceeded, the output switches off.

### **5.3.2 Speed**

With speed monitoring, the output switches off when the configured value is exceeded.



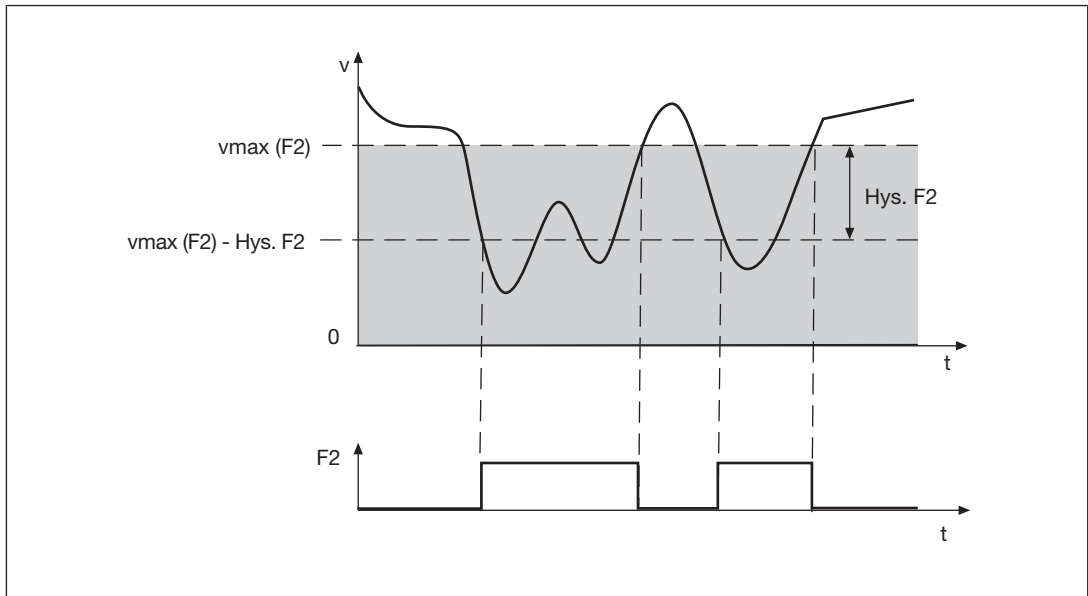

Fig.: Sequence of standstill and speed monitoring process

### 5.3.3 Speed range

With range monitoring, the output switches off if the rotational speed (velocity, frequency) is outside the configured range.

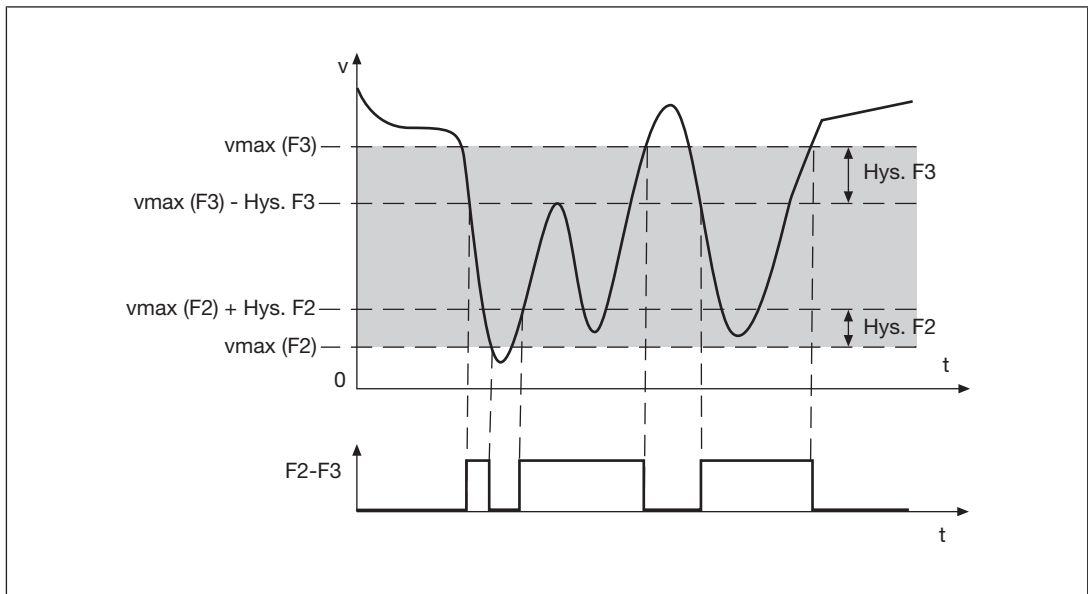

Fig.: Sequence of speed range monitoring process

### 5.3.4 Position

When position monitoring is active, the current position is taken as a reference position in the middle of the position window (configured window width), and the assigned output is switched on. The output will stay switched on provided the current position is within the position window. A max. 4 positions to be monitored can configured at the same time.

If the position moves outside the configured range, position monitoring is deactivated and the assigned outputs are switched off.

Position monitoring can be started (activated) automatically or monitored:

► **Monitored start (default)**

- Position monitoring is started when a rising edge has been detected at the start input.
- Active position monitoring is not started again by another rising edge at the start input (retriggering is not possible).
- Active position monitoring continues unchanged even if a different parameter set is selected, which also uses position monitoring. This also applies if position monitoring is used in a different switch function.
- Active position monitoring is reset if another parameter set is selected, which does not use position monitoring.

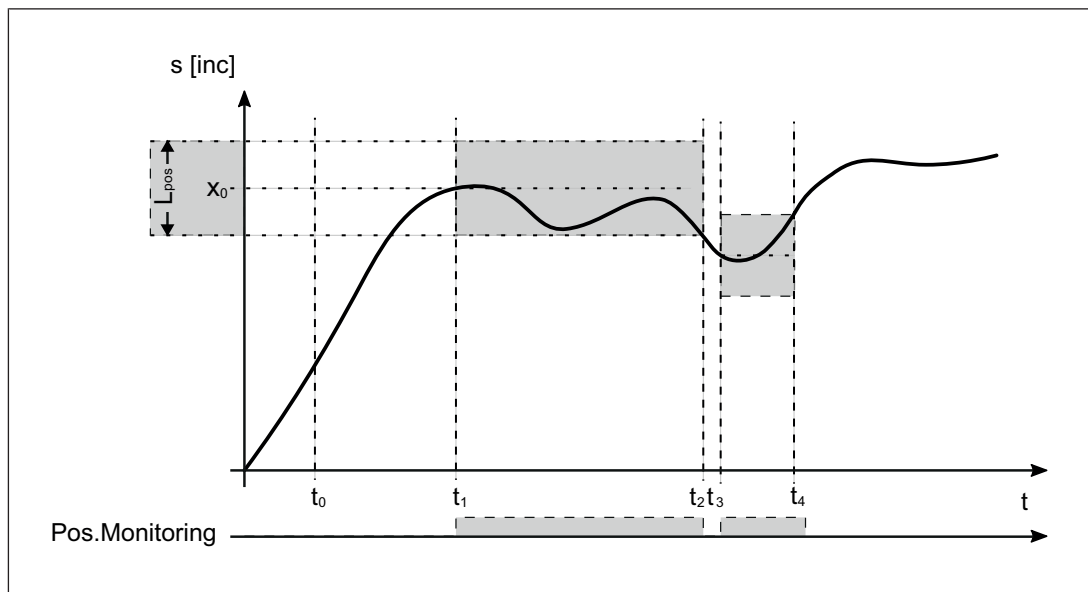

Fig.: Sequence of position monitoring with monitored start

**Legend**

- $x_0$  Reference position
- $L_{pos}$  Position window
- $t_0$  Device on
- $t_1$  Start of position monitoring by rising edge at the start input (S34)
- $t_2$  Position leaves the position window, assigned outputs will switch off
- $t_3$  Restart of position monitoring by rising edge at the start input (S34)
- $t_4$  Position leaves the position window, assigned outputs will switch off

► **Automatic start**

- Position monitoring is started when a rising edge has been detected at the start input.
- Position monitoring is started when the parameter set has been switched over and position monitoring is used in the current parameter set.
- Position monitoring is restarted when the limit value has been exceeded and a rising edge has been detected at the start input.
- Active position monitoring is not started again by another rising edge at the start input.

- Active position monitoring is restarted if another parameter set is selected, which also uses position monitoring. This also applies if position monitoring is used in a different switch function.
- Active position monitoring is deactivated if another parameter set is selected, which does not use this position monitoring.

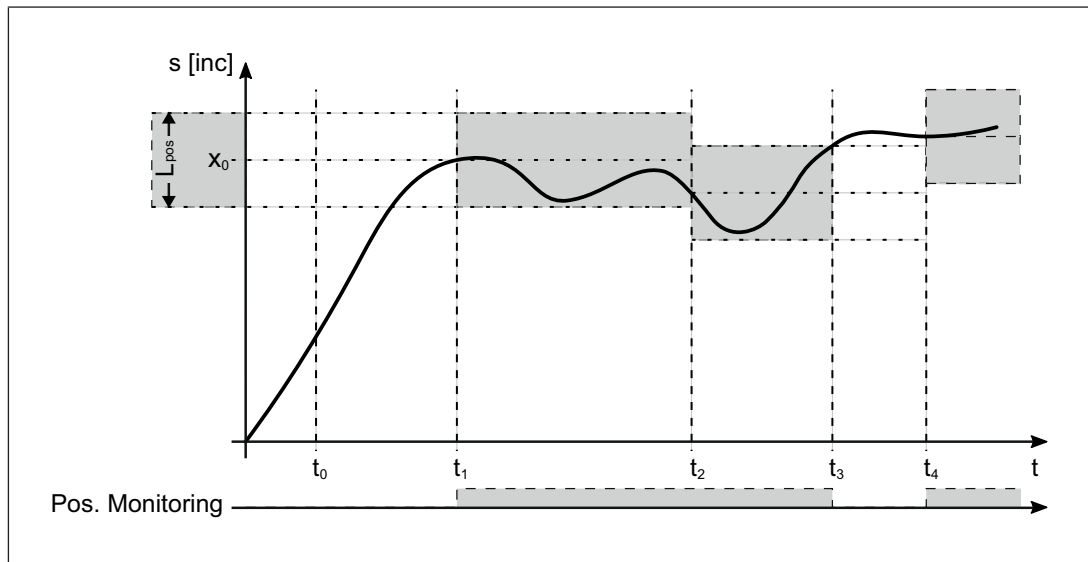

Fig.: Sequence of position monitoring with automatic start

### Legend

- $x_0$  Reference position
- $L_{pos}$  Position window
- $t_0$  Device on
- $t_1$  Start of position monitoring by selecting a parameter set via the Select inputs
- $t_2$  Position monitoring is restarted by selecting a different parameter set
- $t_3$  Position leaves the position window, assigned outputs will switch off
- $t_4$  Restart of position monitoring by rising edge at the start input (S34)

### Please note:

- ▶ Position monitoring cannot be used if proximity switches are employed.
- ▶ Managing the start type of the outputs is independent of the start type of the position monitoring.
- ▶ In the event of an open circuit, position monitoring is automatically deactivated

## 5.3.5

### Direction

If the direction is to be detected safely, this function must be linked to a safety contact.

#### ▶ Clockwise

If "Direct. Right" is configured, the safety output is switched on during normal operation in clockwise rotation.

#### ▶ Counter-clockwise

If "Direct. Left" is configured, the safety output is switched on during normal operation in anti-clockwise rotation.

► **Tolerance**

For both directions, a tolerance can be entered for the wrong direction. This means that the drive may run in the incorrect direction until it reaches the set tolerance value without the assigned output switching off.

A switched off output cannot switch on again until the drive has moved up to the tolerance value in the correct direction.

The tolerance is also taken into account following an automatic reset.

► **Automatic reset**

For both directions, a joint automatic reset can be configured.

- If no automatic reset is configured, the direction monitoring is reset only by switching off the supply voltage.
- When automatic reset is configured, the direction monitoring is reset when a parameter set is switched over.

Please note:

- Direction monitoring is always active, irrespective of whether it is used in the selected parameter set.
- Direct.Right and Direct.Left are active when the PNOZ s30 is started up.
- Direction cannot be detected if proximity switches are used.

Timing diagram for direction monitoring:

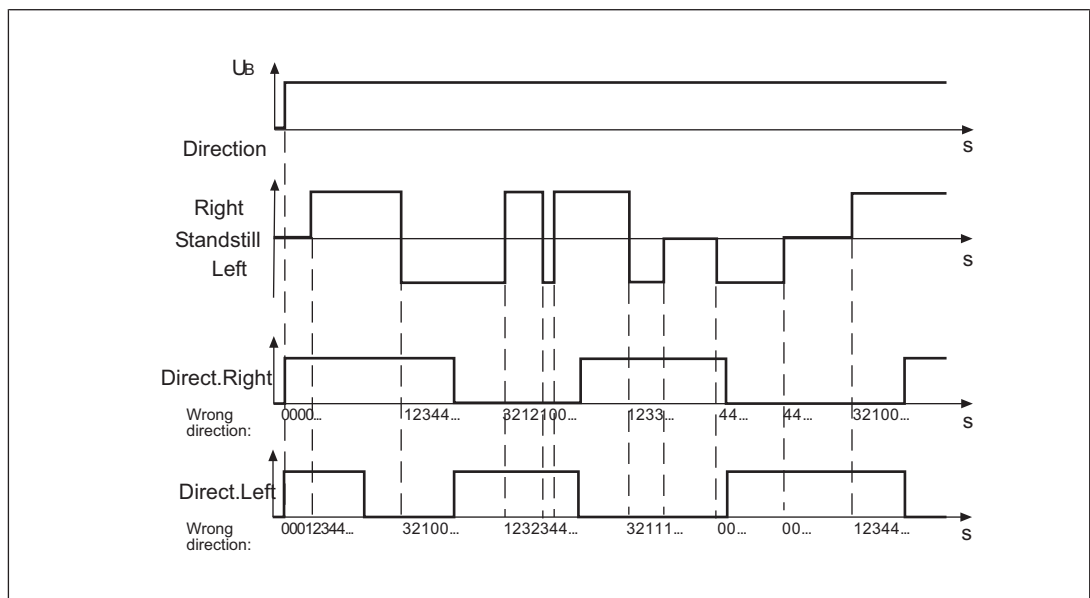

Configuration in the example:

- Wrong direction in anti-clockwise rotation  
Max. right: 3 pulses
- Wrong direction in clockwise rotation  
Max. left: 3 pulses

### 5.3.6 2 encoder diagnostics / broken shearpin monitoring

To increase the safety level of an encoder and for broken shearpin monitoring, an additional proximity switch or an HTL signal from an additional encoder can be connected to track Z. These must both be configured as Z-frequency monitoring.

A monitoring function checks that the frequency difference on the tracks AB " $f_{AB}$ " to track Z " $f_Z$ " is less than 10%.

**Please note:**

Monitoring for broken shearpins does not become active until

- ▶ The minimum speed has been exceeded and
- ▶ The tolerance for detecting plausibility errors has elapsed.
- ▶ Testing has not been deactivated via the parameter sets and input wiring.

The minimum speed and tolerance depend on

- ▶ The ratio of the frequency at tracks AB " $f_{AB}$ " to the frequency at track Z " $f_Z$ " in your configuration ( **$f_{AB}/f_Z$  Verh.** setting in the menu) and
- ▶ The configured activation speed ( $v_{ABZ}$  setting in the menu)

Minimum speed:

- ▶ when  **$f_{AB}/f_Z$  Verh.**  $\geq 1.0$   
 $f_Z = 10$  mHz or  $f_{AB} = (f_{AB}/f_Z) \times 10$  mHz
- ▶ when  **$f_{AB}/f_Z$  Verh.**  $< 1.0$   
 $f_{AB} = 10$  mHz or  $f_Z = 10 \text{ mHz} / (f_{AB}/f_Z)$
- ▶  $f_{AB} \geq v_{ABZ}$  or  $f_Z \geq v_{ABZ} / (f_{AB}/f_Z)$

Tolerance for detecting plausibility errors:

- ▶ when  **$f_{AB}/f_Z$  Verh.**  $\geq 1.0$   
7.5 Z-pulses or  $7.5 \times (f_{AB}/f_Z)$  AB-pulses
- ▶ when  **$f_{AB}/f_Z$  Verh.**  $< 1.0$   
4.5 AB-pulses or  $4.5 / (f_{AB}/f_Z)$  Z-pulses

### 5.3.7 Hysteresis

For each switch function F1 ... F9 (with the exception of direction and position), a hysteresis can be configured. This prevents the outputs on the speed monitor from bouncing if there are fluctuations around the response value. The hysteresis becomes effective when the output is switched on:

Switch-on value = switching threshold – hysteresis

For the lower range limit:

Switch-on value = switching threshold + hysteresis

### 5.3.8 Frequency filtering

Measurement value filtering can be configured to suppress rotational speed overshoots or EMC disturbances.

The measured rotational speed is then filtered before it is supplied to the monitoring functions standstill or speed monitoring.

The filter can be configured as slow, average or fast.



**NOTICE**

**Please note:**

The reaction time after the limit value is exceeded, as specified in the technical details, is increased by filtering.

**Effect of frequency filtering, as an example**

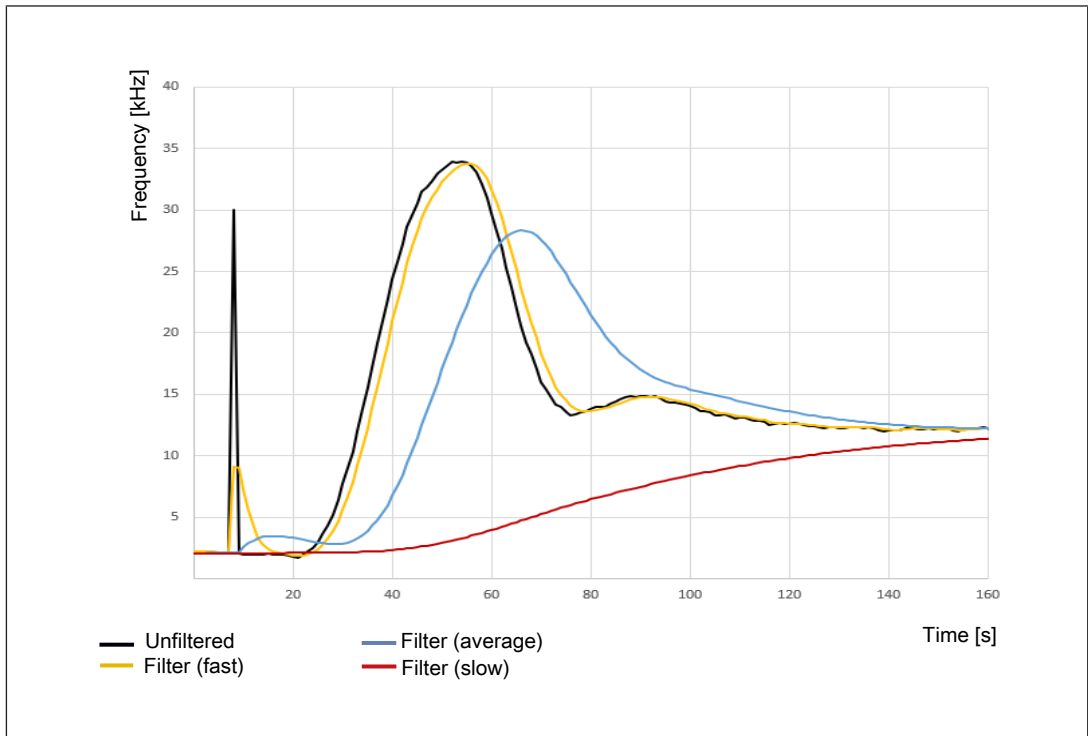

### Step response of slow filter

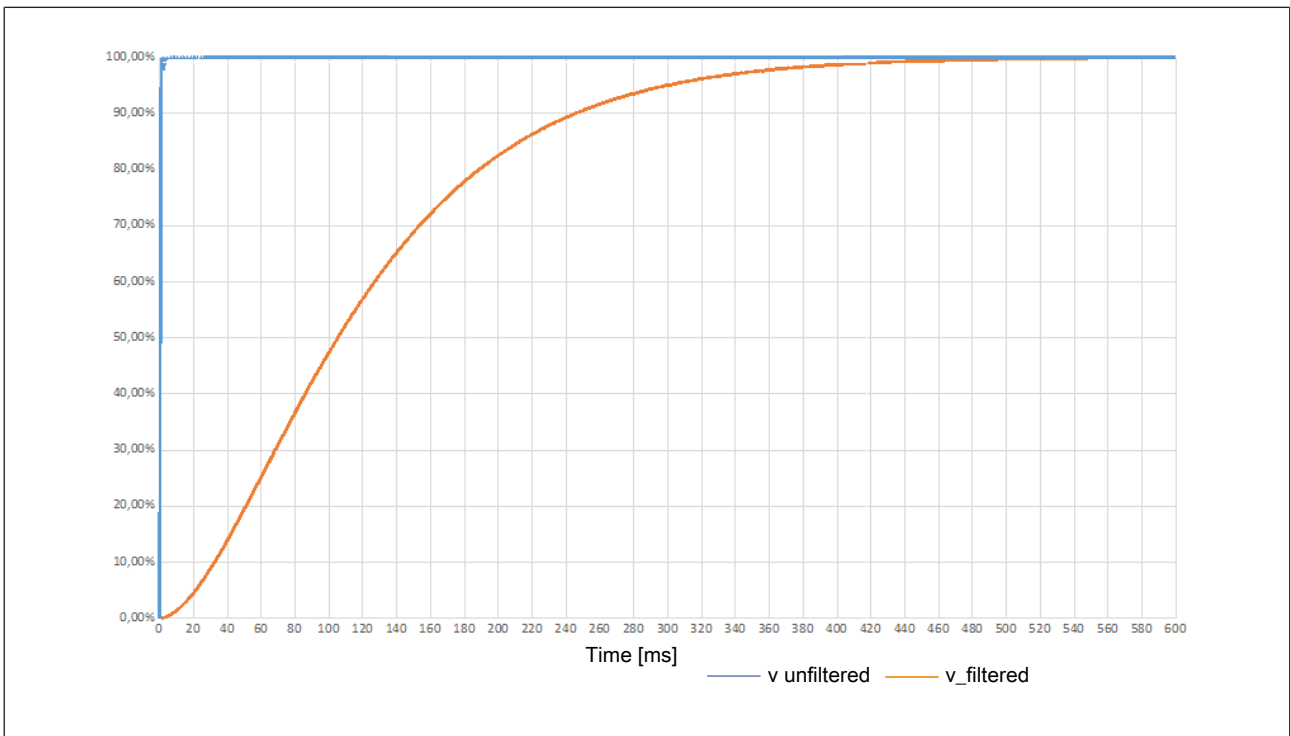

The diagram shows the reaction of the slow filter to a speed change at the input. The filter achieves 99% of the set end value after approx. 420 ms.

### Step response of average filter

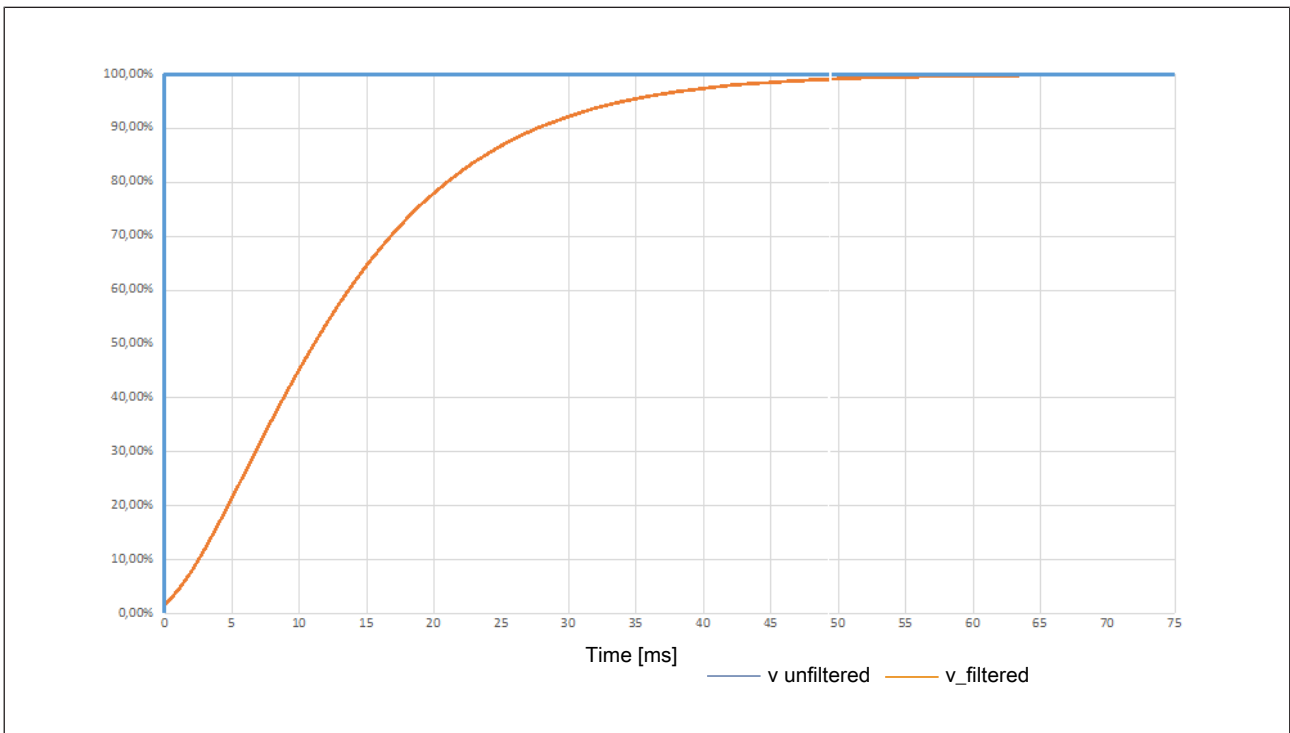

The diagram shows the reaction of the average filter to a speed change at the input. The filter achieves 99% of the set end value after approx. 47 ms.

### Step response of fast filter

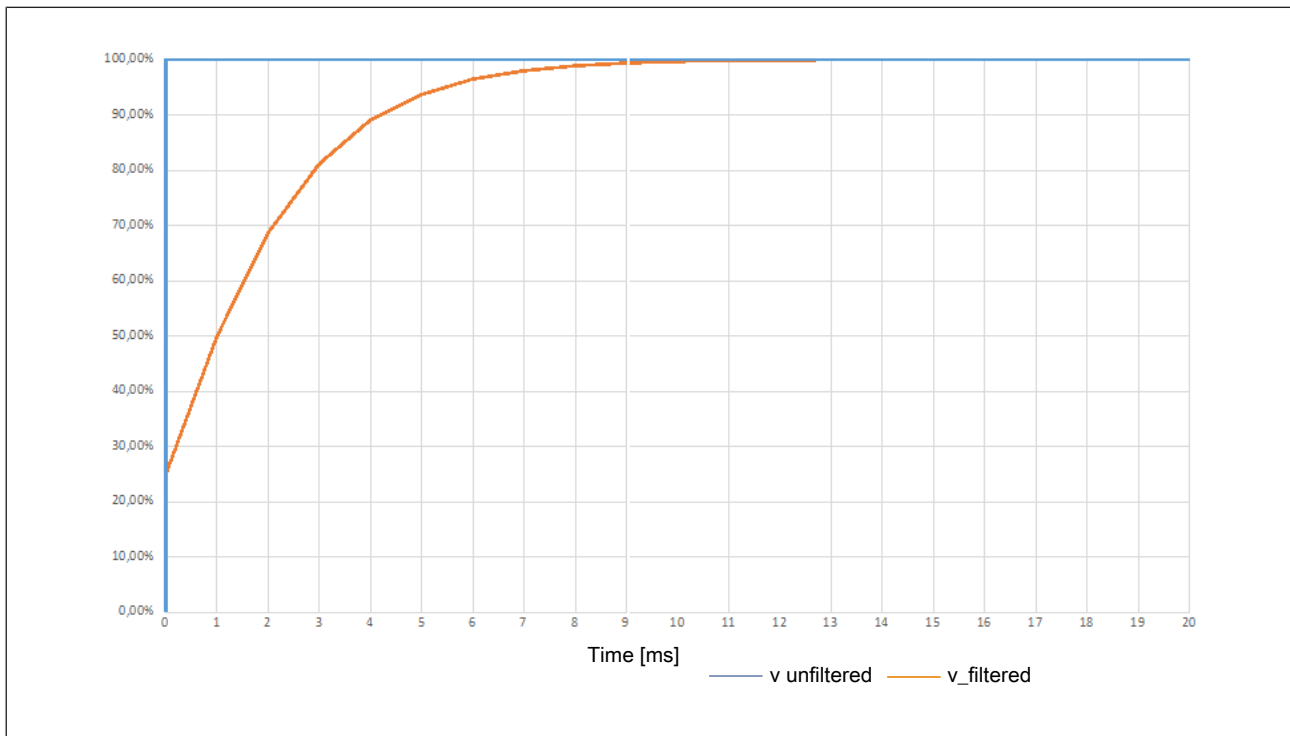

The diagram shows the reaction of the fast filter to a speed change at the input. The filter achieves 99% of the set end value after approx. 9 ms.

### 5.3.9 Start types

You can choose between the following start modes:

#### ▶ Automatic start

If an automatic start is configured, the output switches on automatically if the speed does not reach the limit value, for example.

#### ▶ Monitored start with rising edge

If a monitored start with rising edge is configured, the output switches on if the speed does not reach the limit value and then a rising edge was detected at S34.

#### ▶ Monitored start with falling edge

If a monitored start with falling edge is configured, the output switches on if the speed does not reach the limit value and then a falling edge was detected at S34.

### 5.3.10 Start-up delay

A start-up delay time can be configured, which prevents the evaluation of the encoder signals for the configured time period after the supply voltage is switched on.

### 5.3.11 Synchronous start

Outputs can be combined into a group with the "Synchronous start" option.

It is ensured that all the outputs in this group must be switched off before an individual output in this group can be switched on again.



To switch on an output in this group, all the other start-up conditions for this output must be met. The outputs in the group are switched on independently of each other.

Please note:

- ▶ No switch-on delay may be configured for synchronous outputs (menu Output delay:Switch-on delay/switch-on and switch-off delay).

### 5.3.12 Outputs

The device has 2 relay outputs, four semiconductor outputs (auxiliary outputs) and an expansion interface for 2 more safe relay outputs, which can be controlled separately.

#### Relay outputs

The relay outputs Rel. 1 and Rel. 2 are safety outputs, which are designed diversely. The second shutdown route is via a common root relay (called "Relay control" in the block diagram). This means that, should an error occur, in the event of a welded relay contact for example, both relay outputs are shut down via the root relay.

Rel. 1: Terminals 13-14

Rel. 2: Terminals 23-24

#### Semiconductor outputs

The semiconductor outputs Out 1 to Out 4 are outputs for standard applications.

The semiconductor outputs can be operated in normally de-energised or normally energised mode.

Out 1: Terminal Y32

Out 2: Terminal Y33

Out 3: Terminal Y34

Out 4: Terminal Y35

#### External outputs on the expansion interface

The external outputs Ext.1 and Ext. 2 can be used for more safe relay outputs. To do this, connect an appropriate expansion module to the expansion interface.

### 5.3.13 Switch delay

A delay time can be set for each output (see technical details). The outputs will not switch until the set time has elapsed. It is possible to configure whether the delay time is to be activated when switching on, switching off, or switching on and off.

**WARNING!****Potential loss of safety function due to increased reaction time**

The output switch-off delay ( $t_{do, Off}$ ) when overspeed is reached will increase the speed monitor's reaction time by the stated value (see technical details). This must not delay the arrival of a safe condition by more than the permitted time. The configuration of the switch-off delay must be considered in the risk assessment as regards hazards, reaction time and safety distance.

The following delay types can be configured:

**Switch-on delay retriggerable  $\gg$** 

After a rising edge (e.g speed is in the permitted range) the output will switch on only when the configured time has elapsed. When there is another rising edge during the delay time, the delay time is restarted.

**Switch-off delay retriggerable  $\gg$** 

After a falling edge (e.g speed is exceeded) the output will switch off only when the configured time has elapsed. At a rising edge during the delay time, the time is reset without the output switching off.

**Switch-on switch-off delay retriggerable  $\gg$   $\gg$** 

After a rising edge the output will switch on only when the configured time has elapsed. After a falling edge (e.g speed is exceeded) the output will switch off only when the configured time has elapsed. When there is another rising or falling edge during the delay time, the delay time is restarted.

**Switch-off delay not retriggerable  $\gg$** 

After a falling edge (e.g speed is exceeded) the output will switch off only when the configured time has elapsed. A rising edge during the delay time has no effect. The output switches off when the time has elapsed.

**5.3.14 Feedback loops**

Feedback loops are used to monitor external contactors or relays. The corresponding feedback loop must be closed before starting.

**5.3.15 Analogue output**

The semiconductor output OUT 4 (Y35) can be configured as 0 – 20 mA or 4 – 20 mA analogue output (burden 0 ... 500 Ohm).

The currently applied frequency is output as a current value that is proportional to the currently applied frequency. Here, the current value rises to the maximum value 20 mA. The relevant frequency  $f_{max}$  can be configured for this maximum value (see "Expanded settings" menu). When the maximum frequency is exceeded, the current value will continue to rise proportionally to approx. 22 mA, and then remains constant.

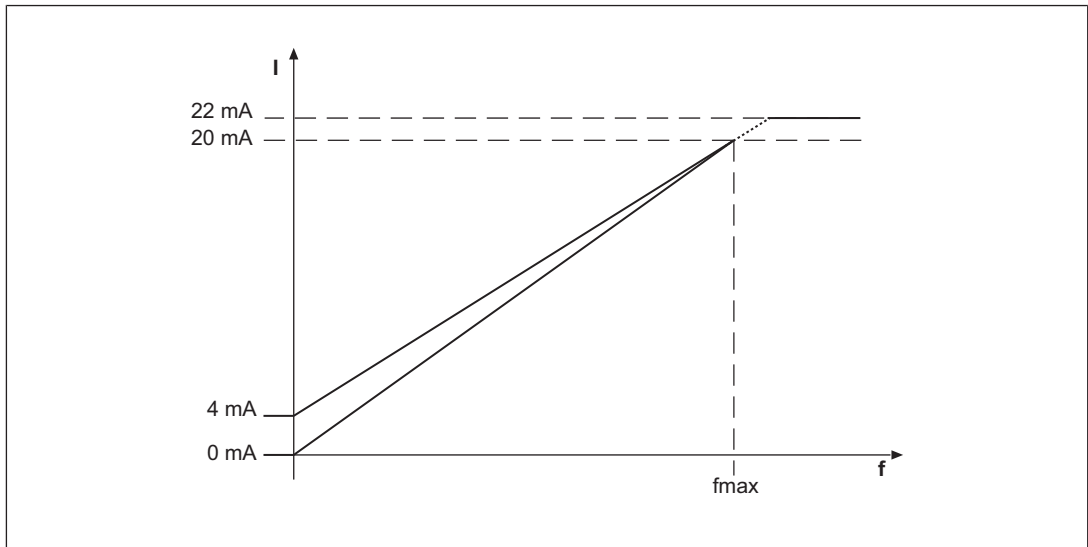

### 5.3.16 Units

The values to be configured can be entered in various units. Depending on the axis type (linear or rotational axis), various units can be selected for speed and distance (see chapter entitled "Menu overview").

### 5.3.17 Timing diagram for speed monitoring

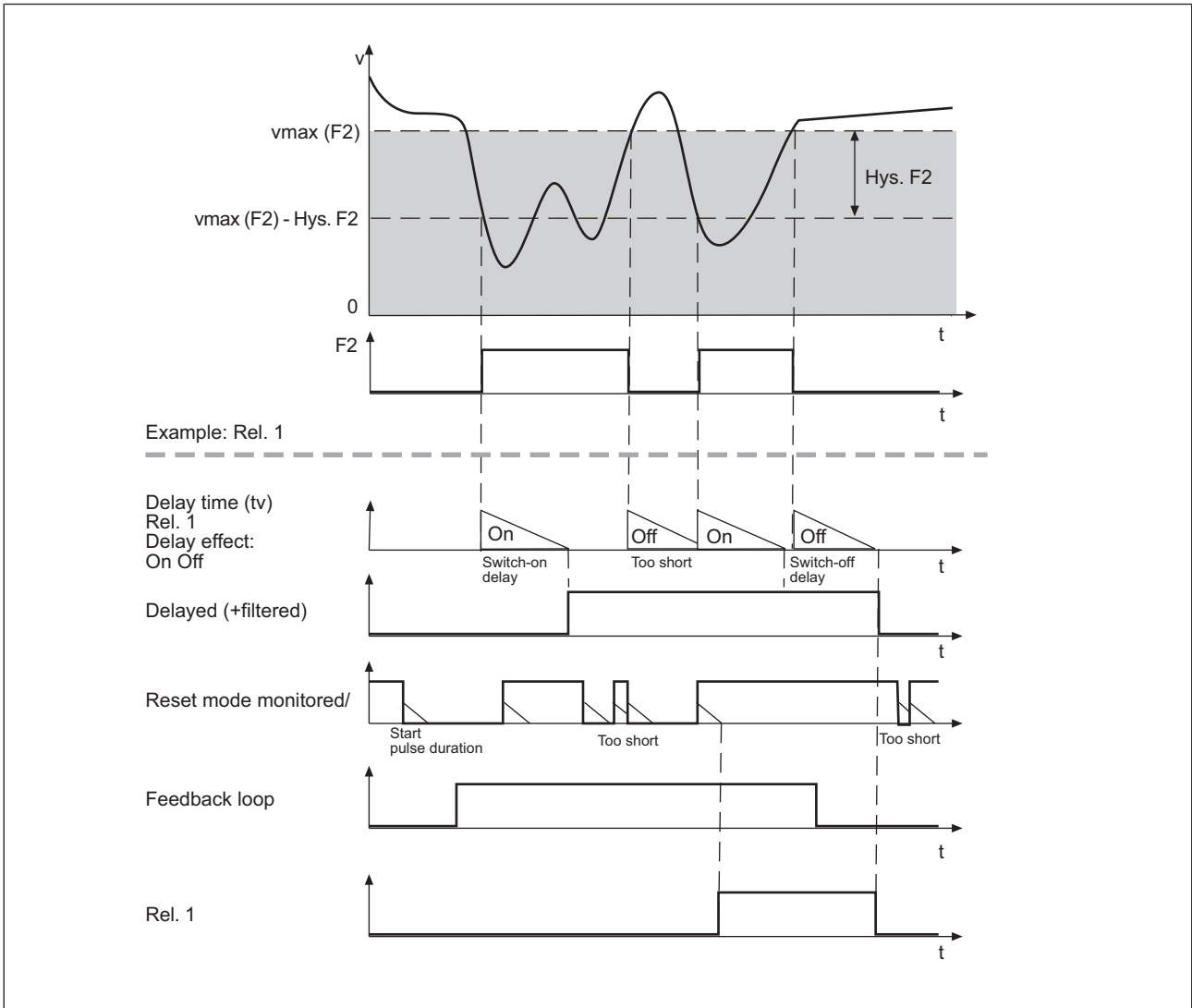

Configuration in the example:

- ▶ Switch function: F2
- ▶ Assigned output: Rel. 1
- ▶ Delay effect on outputs: On + Off
- ▶ Start type: Monitored /

## 5.4 Speed configuration

The speed monitor is configured using the rotary knob on the device.

To monitor e.g. various operating modes you can configure up to 16 parameter sets (P0 ... P15) with a max. of 9 switch functions (F1 ... F9) each.



In addition, special functions may be configured for each parameter set (except in Select mode "None") (see chapter [Special functions](#) [ 34]).

One of the 16 parameter sets is selected via 4 select inputs SEL1 (Y10), SEL2 (Y11), SEL4 (Y12), SEL8 (Y13).

The switching functions are monitored simultaneously.

Each of a switching function's 16 parameters can be configured as

- ▶ Standstill limit
- ▶ Speed limit
- ▶ Upper or lower limit of speed range
- ▶ Right-hand direction monitoring
- ▶ Left-hand direction monitoring
- ▶ Position monitoring 1 to 4 with width of position window 1 to 4
- ▶ Static value "On" or "Off"

Each output can be assigned a switch function or an area. The results of the switch functions can also be linked together logically. A switch function can be assigned to several outputs. A [switch delay](#) [ 25], the [start type](#) [ 24] and [Synchronous start](#) [ 24] can be configured for each output.

If only one parameter set is used, configure the mode "Select inputs: None". The select inputs will then be ignored.



### INFORMATION

2 basic configurations are available for standard applications, for simple configuration within the display menu. A basic configuration contains limited menu functions adapted for standard applications, with partly pre-defined parameters. Further information about basic configurations can be found in this chapter, under "Basic configuration".

### Example configuration:

2 parameter sets for 2 operating modes are configured:

- ▶ Set-up: P0
- ▶ Automatic mode: P1

The parameter set P0 is used to monitor a reduced speed.

The parameter set P1, "Automatic mode", is selected for speed monitoring (selection via the Select inputs, see next chapter "Select inputs").

The following switching functions are configured for the parameter set P0:

- ▶ F1: Standstill 2 Hz
- ▶ F2: Overspeed: 50Hz
- ▶ F3: Warning threshold: 50Hz

The following switch functions are configured for the parameter set P1:

- ▶ F1: Standstill 2 Hz
- ▶ F2: Overspeed: 3000Hz
- ▶ F3: Warning threshold: 2000Hz

The following outputs are assigned to the switch functions:

- ▶ F1: Relay output Rel. 1
- ▶ F2: Relay output Rel. 2
- ▶ F3: Semiconductor output Out 1

language	English	input device								Sin/cos 1Vss	global standstill (10 mHz-1 MHz)	2 Hz	
delay time start-up (0-600s)		Hysteresis (0-50%)									input device settings (10 mHz-1 MHz)	f max (A/B)	20 kHz
units		F1	F2	F3	F4	F5	F6	F7	F8	F9	f max (Z)		
conversion		Standstill	50 Hz	50 Hz							ratio (0,0001-400,000:1)	f(A/B):f(Z)	
mode select input	1 of 4	P0									position monitoring (SOS-M)	reset mode:	
Sel 1 (Y10)		P1	Standstill	3000 Hz	2000 Hz						position window width (1-24,900,000 Imp)	Pos. 1	
Sel 2 (Y11)		P2									Pos. 2		
Sel 3 (Y12)		P3									Pos. 3		
Sel 4 (Y13)		P4									Pos. 4		
delay time select input (0-30s)	20 ms	P5									direction monitoring (SDI-M)	Auto reset:	
assign outputs (functions)		P6									direction tolerance (max. wrong)	direction left	
delay time effect (outputs)		P7									direction right	max. right	
delay time 0-30s (outputs)		P8									direction right	max. left	
reset mode		P9									name of configuration	Example 2	
Synchronous start		P10									CRC of configuration		
output out logic		P11											
Ausgang Out 4 Analog fmax		P12											
		P13											
		P14											
		P15											
		Rel. 1 (13/14)	Rel. 2 (23/24)	Ext. 1	Ext. 2	Out 1 (Y32)	Out 2 (Y33)	Out 3 (Y34)	Out 4 (Y35)				
		F1	F2			F3							
		automatic	automatic			automatic							
		deactivated	deactivated			deactivated							
						normally on							

V.15 - CS-TS - T.U.

For documentation and a better overview of the device settings, we recommend that you fill in this configuration overview before setting the device parameters (see under [Create configuration overview](#) [56]).

From device version 2.2 you have the opportunity to create the settings with the software-tool from Pilz (see [Create configuration in PNOZsigma Configurator](#) [86]).

### 5.4.1 Select Inputs

The parameter sets are selected via the 4 select inputs SEL1 (Y10), SEL2 (Y11), SEL4 (Y12), SEL8 (Y13). Only one of the configured parameter sets can be selected.

One of the following modes can be selected in the "Select inputs mode" menu, depending on the application:

#### "None" mode

For applications up to PL e of EN ISO 13849-1 and up to SIL CL 3 in accordance with EN IEC 62061.

The select inputs are ignored. Only the parameter set P0 is configured and used. The lowest frequency (10 mHz) is automatically set for all other parameter sets.

#### "1 from 4" mode

For applications up to PL e of EN ISO 13849-1 and up to SIL CL 3 in accordance with EN IEC 62061.

A maximum of 4 parameter sets can be configured and used: P1, P2, P4 and P8.

Parameter set	Signal states of the select inputs			
	SEL 8 (Y13)	SEL 4 (Y12)	SEL 2 (Y11)	SEL 1 (Y10)
P1	0	0	0	1
P2	0	0	1	0
P4	0	1	0	0
P8	1	0	0	0

When using these 4 parameter sets, the following safety features are met:

If there is an error when activating the select inputs, such as

- ▶ Short circuits and shorts between contacts
- ▶ Open circuit
- ▶ Drift in the inputs

This may mean that a parameter set other than P1, P2, P4 or P8 is selected. An error message appears and all the outputs switch off.

#### "All 16" mode

In this mode, the number of parameter sets can be increased to max. 16. This mode can only be used for applications up to max. PL d of EN ISO 13849-1 and up to SIL CL 2 of EN IEC 62061.

Parameter set	Signal states of the select inputs			
	SEL 8 (Y13)	SEL 4 (Y12)	SEL 2 (Y11)	SEL 1 (Y10)
P0	0	0	0	0
P1	0	0	0	1
P2	0	0	1	0
P3	0	0	1	1
P4	0	1	0	0

Parameter set	Signal states of the select inputs			
P5	0	1	0	1
P6	0	1	1	0
P7	0	1	1	1
P8	1	0	0	0
P9	1	0	0	1
P10	1	0	1	0
P11	1	0	1	1
P12	1	1	0	0
P13	1	1	0	1
P14	1	1	1	0
P15	1	1	1	1

**When the expanded parameter sets are used, please note the following:**

An open circuit when activating the select inputs triggers a switch to a parameter set with a lower number (e.g. P7 → P3 with open circuit at SEL4).

Limit values for the switch functions should therefore be entered in ascending order (parameter set P0 → lowest values, parameter set P15 → highest values).

For this reason, a special function "No 2 encoder diagnostics" should be configured in a parameter set with a higher number, so that a potential open circuit cannot activate this function unintentionally.

**Delay on the select inputs**

A reaction time can be entered for the select inputs. That way it is possible to filter out invalid signals (e.g. contact bounce or an intermediate state) that occur when switching. The new parameter set will be activated only when the delay time has elapsed.

## 5.4.2 Switch functions

The following switch functions are available:

▶ **Standstill**

The standstill frequency is configured centrally. The standstill frequency should be the lowest frequency in the configuration.

All switch function parameters are pre-configured to the lowest frequency in the factory setting.

▶ **Speed**

Limit values can be configured to monitor for overspeed.

Limit values should be entered in ascending order (Parameter set P0 → lowest values, parameter set P15 → highest values)

▶ **Speed range**

Up to 4 speed ranges can be monitored simultaneously.

Configure two switch functions (speeds) to monitor a range:

- F2 and F3,
- F4 and F5,



- F6 and F7 or
- F8 and F9.

The switch function with the lower number (e.g. F2) operates as the lower range limit; the switch function with the higher number (e.g. F3) operates as the upper range limit.

Both switch functions can be assigned to one or more outputs.

► **Position**

Up to 4 different position windows can be monitored: Position 1 ... Position 4.

Each position to be monitored can be entered as often as necessary in parameter sets P0 to P15 and switch functions F1 to F9.

► **Direction**

The monitoring functions "Direct. Left" and "Direct. Right" can be configured as a switch function as often as necessary.

For both directions, a tolerance can be entered for the wrong direction.

► **Static value "On" or "Off"**

The static value "On" or "Off" can be configured as a switch function instead of a monitoring function. The assigned outputs are then switched on and/or off.

The static value "On" and "Off" can be configured as a switch function as often as necessary.

► **Logic operations**

The results of the switch functions F1 ... F9 and the area operations F2-F3 ... F8-F9 can be linked together logically (AND, OR). The following operations can be assigned:

F2 AND F3 ( $F2 \wedge F3$ )

F4 AND F5 ( $F4 \wedge F5$ )

F1 AND F6-F7 ( $F1 \wedge F6-F7$ )

F1 AND F8-F9 ( $F1 \wedge F8-F9$ )

F6 OR F7 ( $F6 \vee F7$ )

F8 OR F9 ( $F8 \vee F9$ )

F1 OR F2-F3 ( $F1 \vee F2-F3$ )

F1 OR F4-F5 ( $F1 \vee F4-F5$ )

► **Analogue output**

The semiconductor output OUT 4 (Y35) can be configured as 0 – 20 mA or 4 – 20 mA analogue output.

► **Error output**

Every output can be configured as an error output.

Error: Output switched off

No error: Output switched on

► **Output OFF**

Every output can be switched off permanently

**Overview output assignments**

Every assignment has a unique number.

The assignment options are available:

No.	On the display	Description	
0	Off		
1	F1	Individual switch functions	
...			
9	F9		
10	F2 - F3	Speed range	
11	F4 - F5		
12	F6 - F7		
13	F8 - F9		
14	Err	Error output	
15	$F2 \wedge F3$	F2 AND F3	Logic operations
16	$F4 \wedge F5$	F4 AND F5	
17	$F1 \wedge F6-F7$	F1 AND F6-F7	
18	$F1 \wedge F8-F9$	F1 AND F8-F9	
19	$F6 \vee F7$	F6 OR F7	
20	$F8 \vee F9$	F8 OR F9	
21	$F1 \vee F2-F3$	F1 OR F2-F3	
22	$F1 \vee F4-F5$	F1 OR F4-F5	
23	0 – 20 mA Analogue	Analogue output	
24	4 – 20 mA Analogue		

### 5.4.3 Special functions

In Select mode "1 of 4" or "all 16", additional special functions can be configured in addition to the switching functions for each parameter set (P0 to P5).

Special functions cannot be configured in the select mode "none".

The following configuration options are available:

► **No special function (default)**

No special function is performed in the selected parameter set.

► **No 2 encoder diagnostics**

There is no plausibility check between fAB and fZ. This special function may only be used when one of the following encoder types is configured:

- HTL single Z Freq. Ini pnp
- TTL single Z Freq. Ini pnp
- TTL differential Z Freq. Ini pnp
- HTL differential Z Freq. Ini pnp
- sin/cos 1 Vss Z Freq. Ini pnp

- Hiperface Z Freq. Ini pnp

For a parameter set with the special function "No 2 encoder diagnostics" the operating mode without Z Freq. Ini pnp must be used for the safety assessment.

Please note that the "Select inputs mode" setting may reduce the safety level (see under [Select Inputs](#)  31]).

▶ **Error acknowledgement**

When switching to the parameter set, the recoverable errors are acknowledged. Errors that occur while the parameter set is executed are not acknowledged. After error acknowledgement the device behaves in accordance with the switching functions configured in this parameter set. A new error acknowledgement by this parameter set can only be performed after selecting another parameter set.

A complete list of recoverable errors can be found under [Current error messages](#)  91].

The error acknowledgement restarts the PNOZ s30.

▶ **Restart**

The device is restarted when switching to the parameter set.

After restart the device behaves in accordance with the switching functions configured in this parameter set. A new restart by this parameter set can only be performed after selecting another parameter set.

## 5.4.4 Basic configuration

Two basic configurations are available for standard applications, for simple configuration within the display menu. A basic configuration contains limited menu functions adapted for standard applications, with partly pre-defined parameters.

The following basic configurations are available:

**Basic configuration 1:** Ini pnp pnp (proximity switch)

Pre-defined settings and configuration options:

▶ **Encoder type**

2 pnp type proximity switches

▶ **Switch functions**

– **Standstill (F1)**

Standstill frequency configurable in Hz

Default: 2 Hz

– **Speed (F2)**

Max. frequency (v max) configurable in Hz

Default: 500 Hz

▶ **Parameter set/select input**

P0, select inputs are ignored ("None" mode")

▶ **Hysteresis**

Standstill and speed, 2 % each

▶ **Output assignment**

- Standstill (F1): Relay output Rel. 1 and semiconductor output Out 1

- Speed (F2): Relay output Rel. 2 and semiconductor output Out 2

▶ **Start mode**

- Rel. 1, Rel. 2 Out 1, Out 2: Automatic start

▶ **Switch delay**

None

▶ **Max. encoder frequency**

3.5 kHz

**Basic configuration 2: Encoder**

▶ **Encoder type**

Encoder

- Encoder type configurable

▶ **Switch functions**

– **Standstill (F1)**

Standstill frequency configurable in Hz

Default: 100 Hz

– **Speed (F2)**

Max. frequency (v max) configurable in Hz

Default: 5 kHz

– **Direction (F3)**

Left direction

Tolerance for wrong direction = 10 pulses

– **Direction (F4)**

Right direction

Tolerance for wrong direction = 10 pulses

▶ **Parameter set/select input**

P0, select inputs are ignored ("None" mode")

▶ **Hysteresis**

Standstill and speed, 2 % each

▶ **Output assignment**

- Standstill (F1): Relay output Rel. 1 and semiconductor output Out 1
- Speed (F2): Relay output Rel. 2 and semiconductor output Out 2
- Left direction (F1-F4): External output Ext. 1 and semiconductor output Out 3
- Right direction (F1-F4): External output Ext. 2 and semiconductor output Out 4

▶ **Start mode**

- All outputs: Automatic start

▶ **Switch delay**

None

▶ **Max. encoder frequency**

1 MHz

For details of how to configure the basic configurations, see the chapter entitled Commissioning/Display Menu - Configuration

### 5.4.5 Chip card

The set parameters, the name of the configuration, the check sum and the passwords are stored on the chip card. The error list can also be saved to the chip card. (See chapter "Use chip card").

## 5.5 Input device types

### 5.5.1 Proximity switch

- ▶ The following proximity switches can be used:
  - pnp
  - npn
- ▶ The values stated under [Safety characteristic data \[107\]](#) apply only when using proximity switches that are implemented as N/O contacts.
- ▶ The proximity switches must be fitted so that at least one is always activated. In other words, the proximity switches must be fitted so that the recorded signals always overlap.
- ▶ The cable used to connect the proximity switches must be shielded (see connection diagrams in the chapter entitled "EMC-compliant wiring").
- ▶ The supply voltage of the proximity switches should be monitored via track S.

Proximity switch assembly:

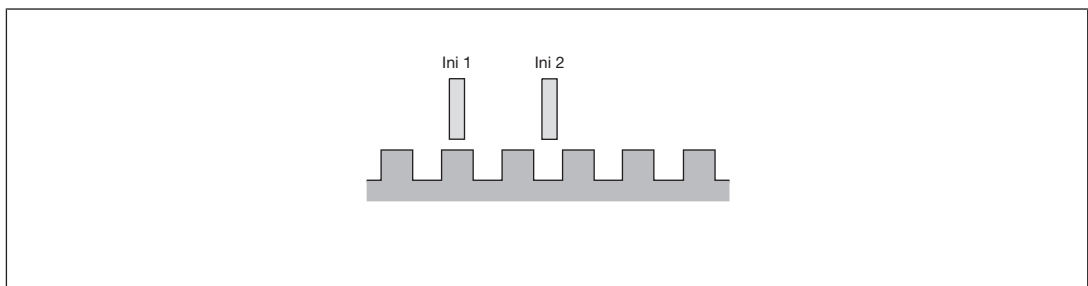

Example pnp – pnp:

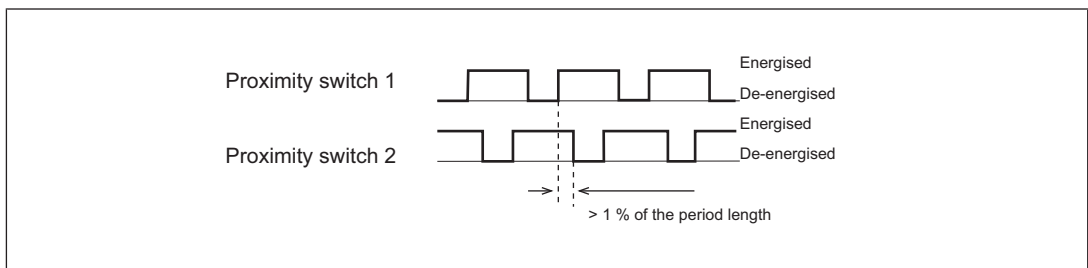



**CAUTION!**

Appropriate installation measures should be taken to prevent a foreign body coming between the signal encoder and the proximity switch. If not, the foreign body could cause invalid signals.

- ▶ Please note the values stated in the technical details
- ▶ The maximum frequency of the used encoders must be entered for a full configuration ("Encoder" menu → "Track AB" → "Track AB fmax" / "Track Z" → "Track Z fmax").
- ▶ The following tolerance times can be configured for the proximity switches:
  - Tolerance time for tracks A and B ("Encoder" menu → "Track AB" → "Track AB Tol.")
  - Tolerance time for track S ("Encoder" menu → "Track S" → "Track S Tol.")

The tolerance time influences the sensitivity towards invalid signal levels (e.g. in the event of EMC interference). The greater the configured tolerance time, the less sensitive the system will be towards invalid signal levels.



**CAUTION!**

**Delayed reaction to invalid signal levels**

Setting a tolerance time increases the reaction time of the feasibility check of the signal levels. The detection time can increase to a maximum of four times the set tolerance time as a result. This must be taken into account when the system is designed.

**Proximity switch with reduce diagnostics**

With the encoder type **2 proximity switches with reduced diagnostics**, the proximity switches can be arranged at will. This means that the signals from the proximity switches do not need to overlap. However, this leads to reduced diagnostics.

## 5.5.2 Rotary encoders

- ▶ The following encoders can be used:
  - TTL, HTL (single-ended or differential signals)
  - sin/cos 1 Vss
  - Hiperface
- ▶ The encoders can be connected with or without Z index (0 index)
- ▶ The cable used to connect the encoders must be shielded (see connection diagrams in the chapter entitled "EMC-compliant wiring").
- ▶ A proximity switch can also be connected to track Z for monitoring broken shearpins
- ▶ Track S can be used:
  - To connect an encoder's error output
  - To monitor voltages between 0 V and 30 V for a permitted upper and lower limit. For example, the encoder's supply voltage can be monitored.

- ▶ The following must be entered for a complete configuration
  - The maximum frequency of the used encoders ("Encoder Settings" menu → "Track AB" → "Track AB fmax" / "Track Z" → "Track Z fmax").
  - When monitoring broken shearpins: The ratio  $f_{AB}/f_Z$  ("Encoder Settings" menu → "Track Z" →  $f_{AB}/f_Z$  Verh.)
- ▶ The following tolerance times can be configured for the rotary encoders
  - Tolerance time for tracks A and B ("Encoder" menu → "Track AB" → "Track AB Tol.")
  - Tolerance time for track Z ("Encoder" menu → "Track Z" → "Track Z Tol.")
  - Tolerance time for track S ("Encoder" menu → "Track S" → "Track S Tol.")

The tolerance time influences the sensitivity towards invalid signal levels (e.g. in the event of EMC interference). The greater the configured tolerance time, the less sensitive the system will be towards invalid signal levels. With encoder types with Z index the tolerance time for tracks A and B is also effective for track Z. The tolerance time for track Z is only effective for the encoder types "rotary encoder + pnp proximity switch".



**CAUTION!**

**Delayed reaction to invalid signal levels**

Setting a tolerance time increases the reaction time of the feasibility check of the signal levels. The detection time can increase to a maximum of four times the set tolerance time as a result. This must be taken into account when the system is designed.

Please note the values stated in the technical details

**5.5.2.1**

**Output signals**

**Output signals TTL, HTL**

- ▶ Single ended

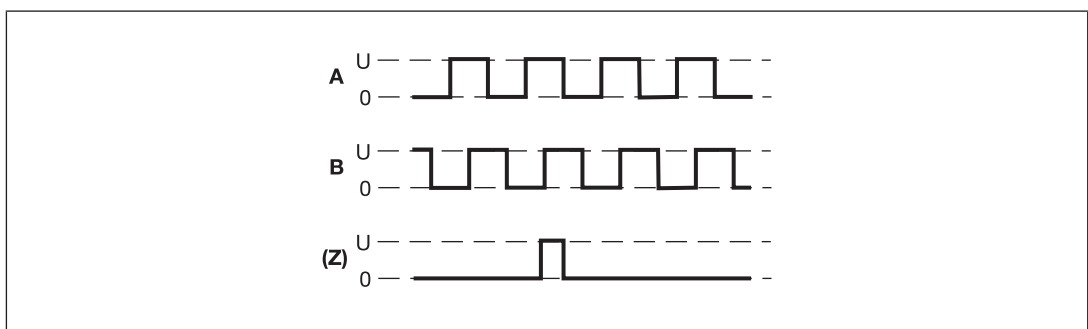

► Differential

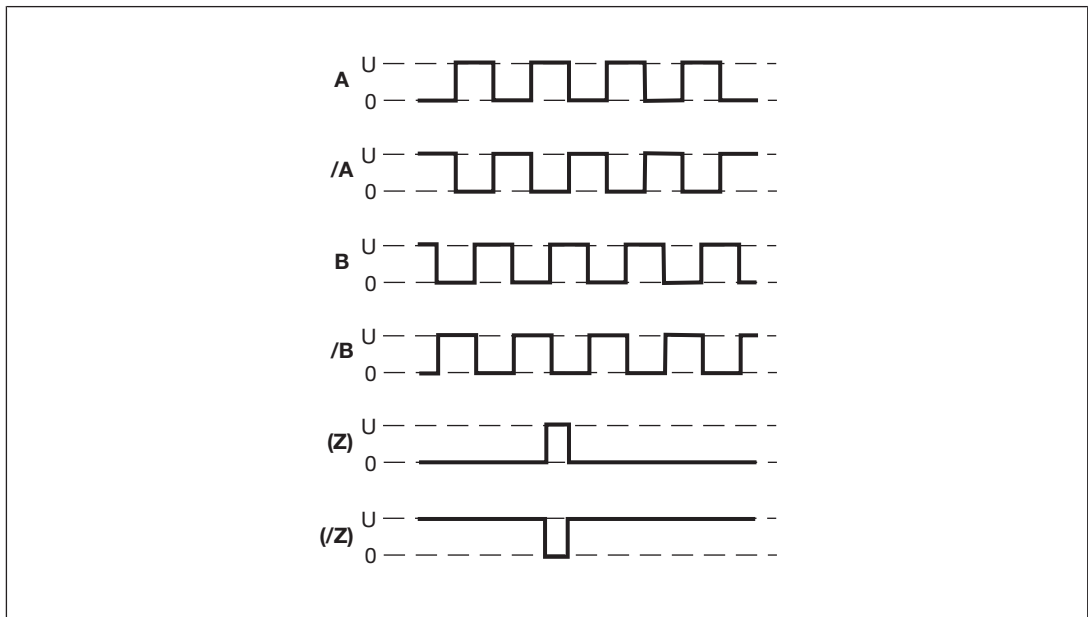

**Output signals Sin/Cos (1 Vss)**

► Single ended with reference track (e.g. Hiperface ®)

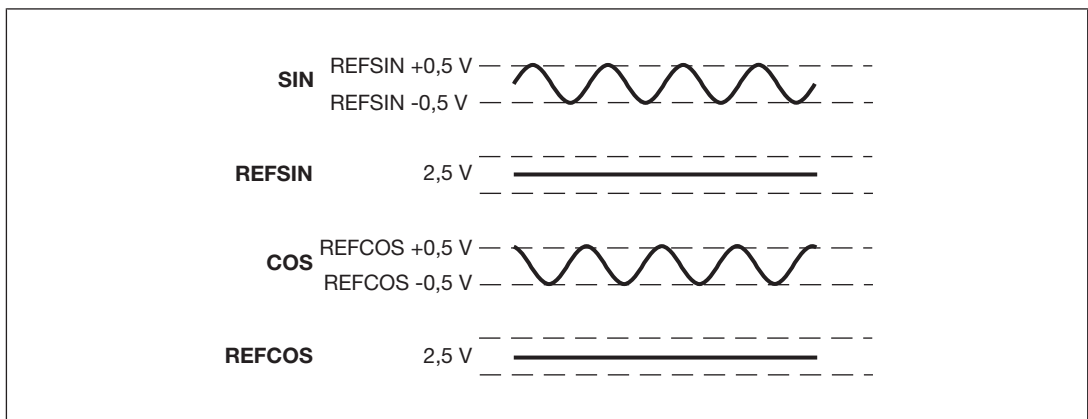



► Differential with/without Z index (e.g. Heidenhain 1 Vss)

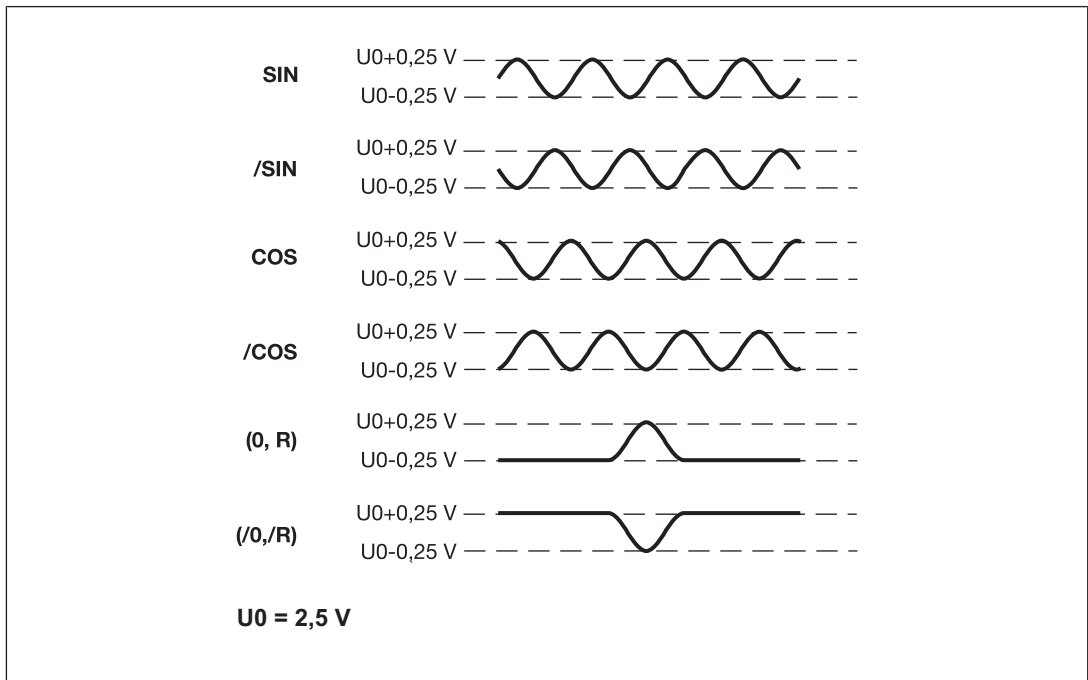

**5.5.2.2**

**Adapter for incremental encoders**

The adapter records the data between the encoder and the drive and makes it available to the PNOZ s30 via the RJ45 socket.

Pilz supplies complete adapters as well as ready-made cable with RJ45 connector, which can be used when making your own adapter. The range of products in this area is constantly being expanded. Please contact us about the range of adapters that is currently available.

Adapters can also be found under [Accessories](#)  127].

## 6 Installation

### 6.1 General installation guidelines

**Install base unit without contact expansion module:**

- ▶ Ensure that the plug terminator is inserted at the side of the unit.

**Connect base unit and PNOZsigma contact expansion module:**

- ▶ Remove the plug terminator at the side of the base unit and at the contact expansion module.
- ▶ Connect the base unit and the contact expansion module to the supplied connector before mounting the units to the DIN rail.

**Control cabinet installation**

- ▶ The unit should be installed in a control cabinet with a protection type of at least IP54.
- ▶ It is preferable to install the device on a horizontal DIN rail in order to ensure the best possible convection.
- ▶ Use the notch on the rear of the unit to attach it to the DIN rail.
- ▶ Push the device upwards or downwards before lifting it from the DIN rail.



#### NOTICE

#### Damage due to electrostatic discharge!

Electrostatic discharge can damage components. Ensure against discharge before touching the product, e.g. by touching an earthed, conductive surface or by wearing an earthed armband.

#### 6.1.1 Dimensions

\*with spring-loaded terminals

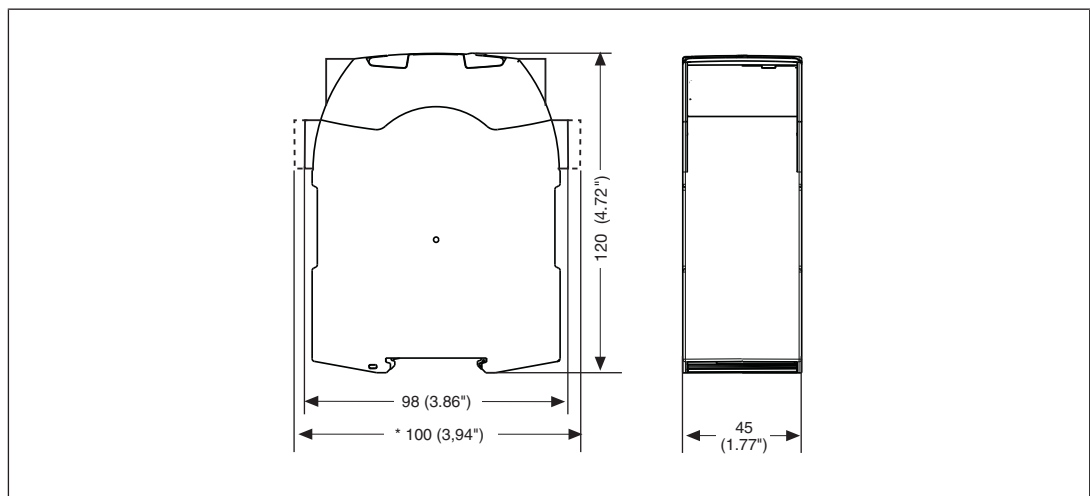

# 7 Wiring

## 7.1 General wiring guidelines

Please note:

- ▶ Information given in the [Technical details \[101\]](#) must be followed.
- ▶ Use copper wiring with a temperature stability of 75 °C.
- ▶ The cable used to connect the encoders and proximity switches must be shielded (see connection diagrams in the chapter entitled "EMC-compliant wiring").
- ▶ The shield may only be connected to earth at a single point.
- ▶ Earth loops should be avoided.
- ▶ If possible, the connections for the various earth potentials (GND, S21, Y30, A2 ) should not be connected on the PNOZ s30 but should be connected directly to the GNDs on the connected units. otherwise noise susceptibility may be increased significantly (conductor loops are not permitted).
- ▶ The cable at the analogue output must be shielded.

## 7.2 Pin assignment of RJ45 socket

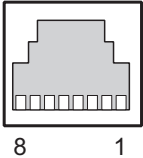
RJ45 socket 8-pin	PIN	Track
	1	S
	2	GND
	3	Z
	4	A
	5	/A
	6	/Z
	7	B
	8	/B

## 7.3 Supply voltage

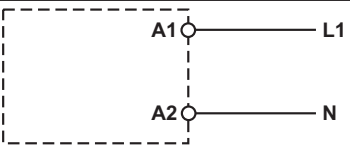
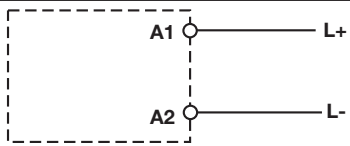
Supply voltage	AC	DC
		

## 7.4 Connection of proximity switches

The following proximity switch combinations can be connected:

- ▶ A: pnp, B: pnp
- ▶ A: npn, B: npn
- ▶ A: pnp, B: npn
- ▶ A: npn, B: pnp

Connection for 2 proximity switches with reduced diagnostics:

- ▶ A: pnp, B: pnp

When connecting proximity switches please note:

- ▶ Proximity switches can either be connected to terminals In1, In2 and GND or to tracks A and B plus GND on the RJ45 socket.
- ▶ Track S should be used to monitor the supply voltage (see drawing). A permitted voltage range can be entered in the menu.
- ▶ Connect the proximity switch to 24 V DC of the power supply.
- ▶ When connecting the proximity switches, please refer to the chapter entitled "EMC-compliant wiring"
- ▶ Invalid signals may occur with cable lengths >50 m. In this case we recommend that you connect a resistor between the signal lines, as shown in the diagrams.

Special features when connecting 2 proximity switches with reduced diagnostics:

- ▶ The cables for connecting the proximity switches must be laid separately.
- ▶ The supply voltage to the proximity switches must be monitored, via track S for example.

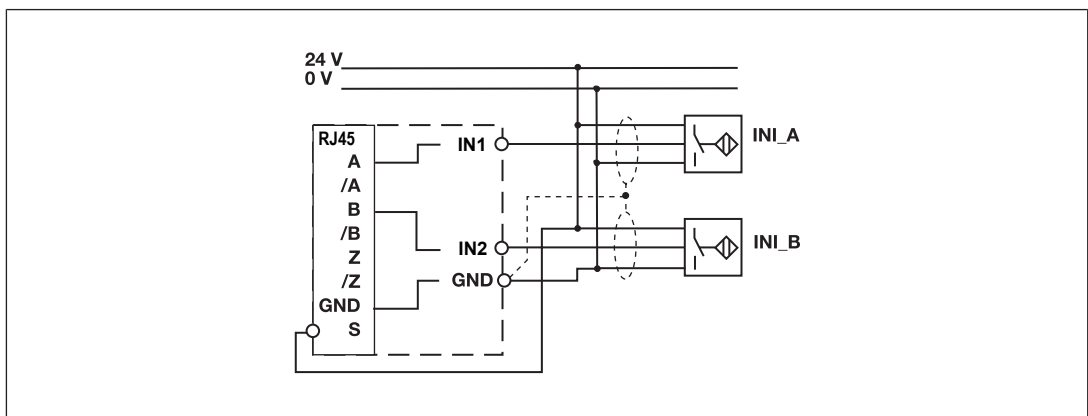

**pnp proximity switch with resistor R = 10 kOhm**

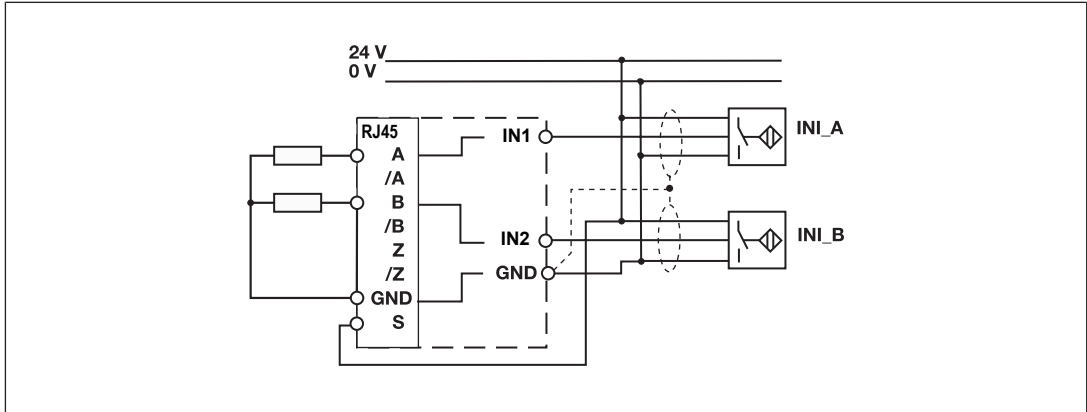

**npn proximity switch with resistor R = 47 kOhm**

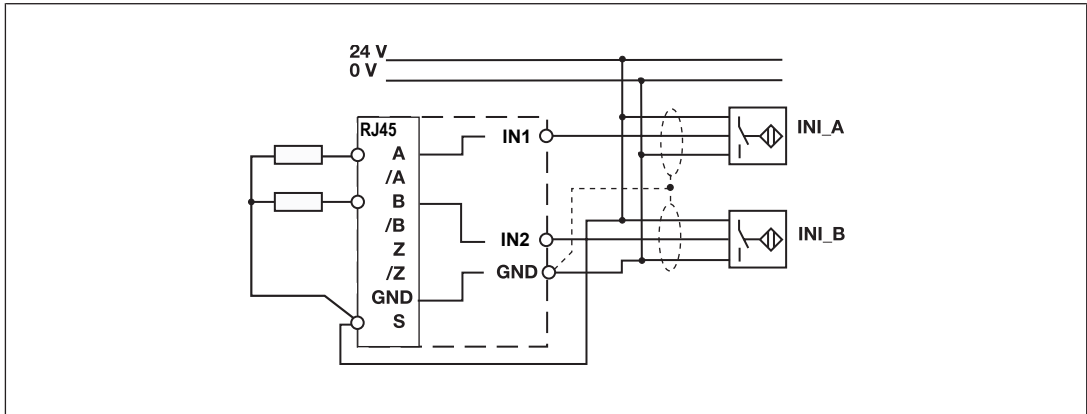

**7.5 Connection of a rotary encoder**

Proceed as follows when connecting the encoder:

- ▶ The encoder can be connected via an adapter (e.g. PNOZ msi6p) or directly to the PNOZ s30.
- ▶ Use only shielded cables for all connections. Please refer to the chapter entitled "EMC-compliant wiring".
- ▶ Always connect GND on the encoder to GND on the RJ45 connector.



**INFORMATION**

The following diagrams are principle connection diagrams. For better clarity, the shielding and supply voltage are not shown.

### 7.5.1 Connect rotary encoder to speed monitor

Encoder types:

- ▶ TTL single ended
- ▶ HTL single ended

Please note:

- ▶ Tracks /A, /B, Z and /Z must remain free

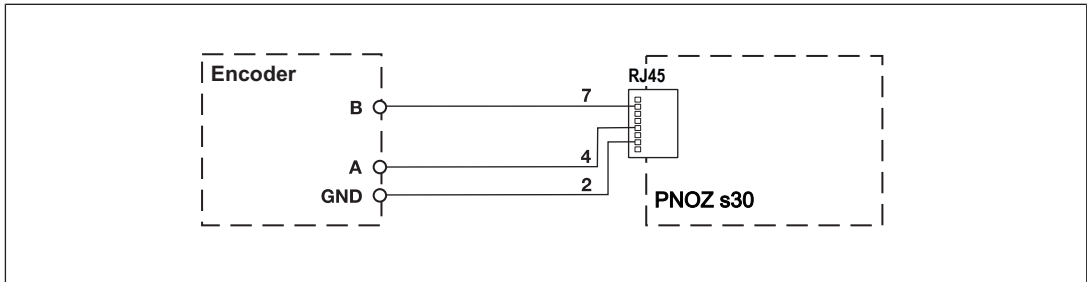

Encoder types:

- ▶ TTL Differential
- ▶ HTL differential
- ▶ sin/cos 1 V<sub>ss</sub>
- ▶ Hiperface

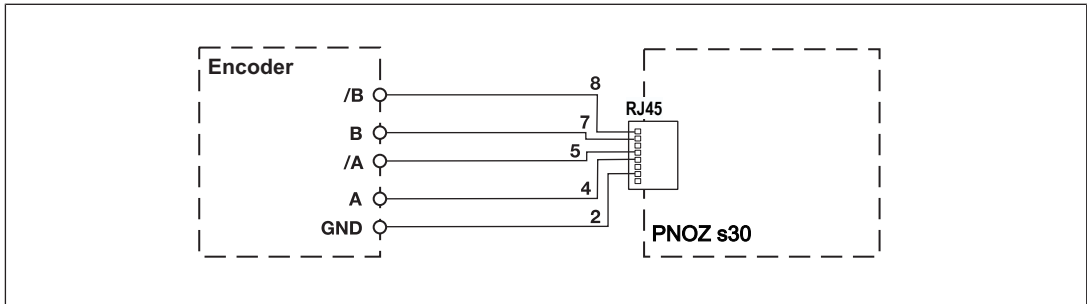

### 7.5.2 Connect rotary encoder with Z index to speed monitor

Encoder types:

- ▶ TTL single ended Z Index
- ▶ HTL single ended Z Index

Please note:

- ▶ Tracks /A, /B and /Z must remain free

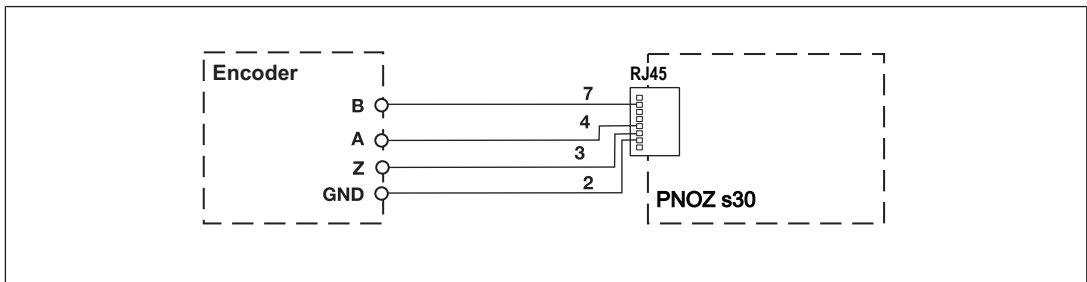

Encoder types:

- ▶ TTL differential + Z Index

- ▶ HTL differential + Z Index
- ▶ sin/cos 1 Vss Z Index

Please note:

- ▶ When using the encoder type sin/cos 1 Vss Z Index, the length of the encoder cable may be max. 30 m.

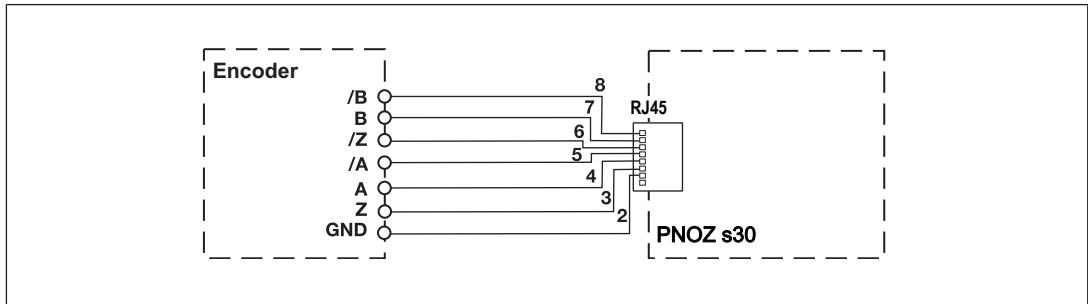

### 7.5.3

#### Connect rotary encoder to the speed monitor via an adapter

The adapter (see Accessories) is connected between the encoder and the drive. The output on the adapter is connected to the RJ45 socket on the PNOZ s30.

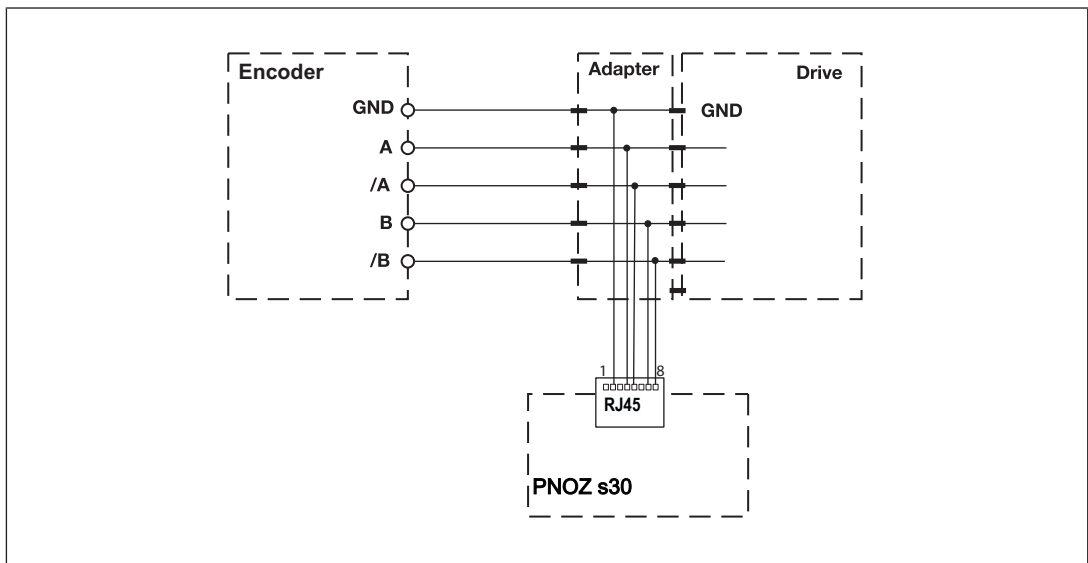

## 7.6 Connection of proximity switch and rotary encoder

When connecting the encoders and proximity switches, please refer to the chapter entitled "EMC-compliant wiring".



### INFORMATION

The following diagrams are principle connection diagrams. For better clarity, the shielding and supply voltage are not shown.

Sensor types:

- ▶ Configuration: HTL single Z Freq. Ini pnp
  - HTL single ended (A,B) + Ini pnp (Z)
  - HTL single ended (A,B) + HTL differential (A as Z)
  - HTL single ended (A,B) + HTL single ended (A as Z)
- ▶ Configuration: TTL single Z Freq. Ini pnp
  - TTL single ended (A,B) + Ini pnp (Z)
  - TTL single ended (A,B) + HTL differential (A as Z)
  - TTL single ended (A,B) + HTL single ended (A as Z)

Please note:

Tracks /A, /B and /Z must remain free.

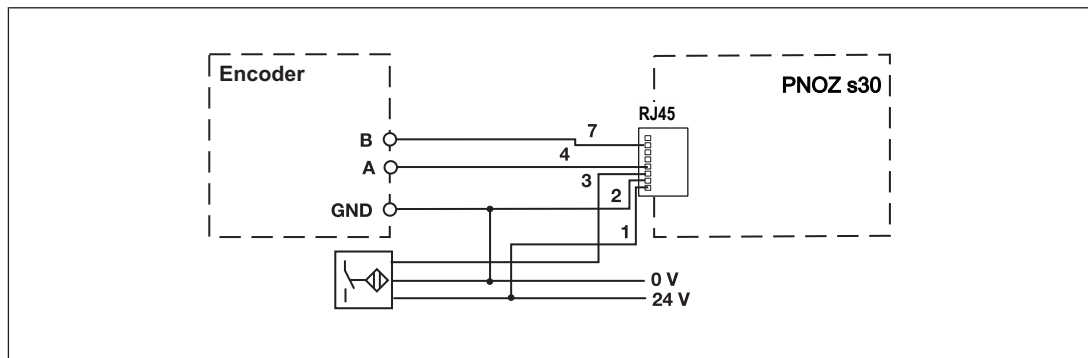

Sensor types:

- ▶ Configuration: TTL differential Z Freq. Ini pnp
  - TTL differential (A,/A,B,/B) + Ini pnp (Z)
  - TTL differential (A,/A,B,/B) + HTL differential (A as Z)
  - TTL differential (A,/A,B,/B) + HTL single ended (A as Z)
- ▶ Configuration: HTL differential Z Freq. Ini pnp
  - HTL differential (A,/A,B,/B) + Ini pnp (Z)
  - HTL differential (A,/A,B,/B) + HTL differential (A as Z)
  - HTL differential (A,/A,B,/B) + HTL single ended (A as Z)
- ▶ Configuration: sin/cos 1 Vss Z Freq. Ini pnp
  - sin/cos 1 Vss (A,/A,B,/B) + Ini pnp (Z)
  - sin/cos 1 Vss (A,/A,B,/B) + HTL differential (A as Z)



- sin/cos 1 Vss (A,/A,B,/B) + HTL single ended (A as Z)
- ▶ Configuration: Hiperface Z Freq. Ini pnp
  - Hiperface (A,/A,B,/B) + Ini pnp (Z)
  - Hiperface (A,/A,B,/B) + HTL differential (A as Z)
  - Hiperface (A,/A,B,/B) + HTL single ended (A as Z)

Please note:

Track /Z must remain free!!

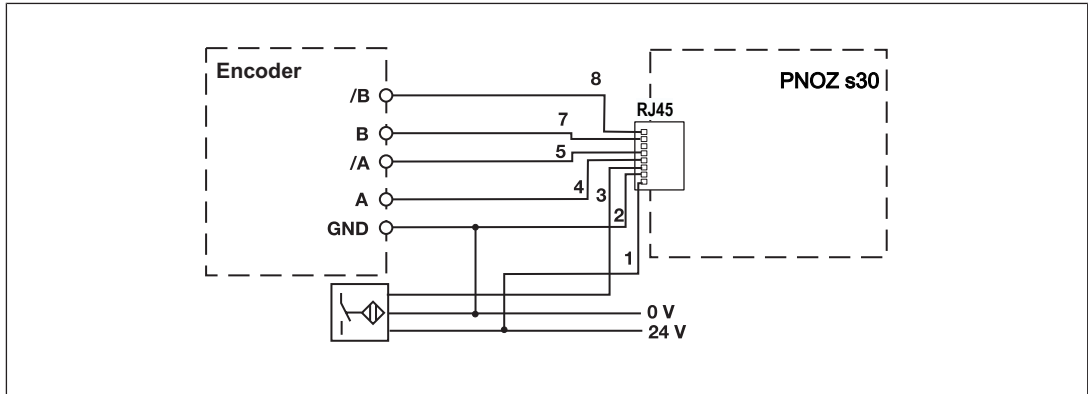

## 7.7

### Reset circuit

Automatic start	Monitored start
automatic start must only be configured No wiring necessary!	



#### NOTICE

#### With automatic start

The unit starts up automatically when the safeguard is reset, e.g. when the E-STOP pushbutton is released. Use external circuit measures to prevent an unexpected restart.

## 7.8

### Feedback circuit

No feedback loop monitoring	Contacts from external contactors

Please note:

When using the feedback loop, the cable run at S34, Y1, Y2 and S11 may be max. 30 m.

For greater cable runs, shielded cables with earthing at either end must be used.

## 7.9 Select inputs

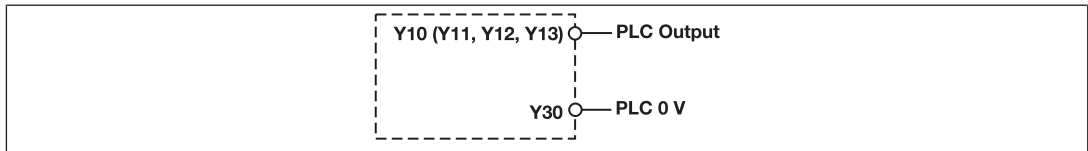

## 7.10 Semiconductor outputs

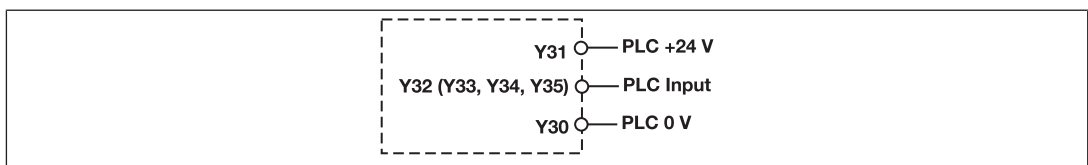

## 7.11 Analogue output

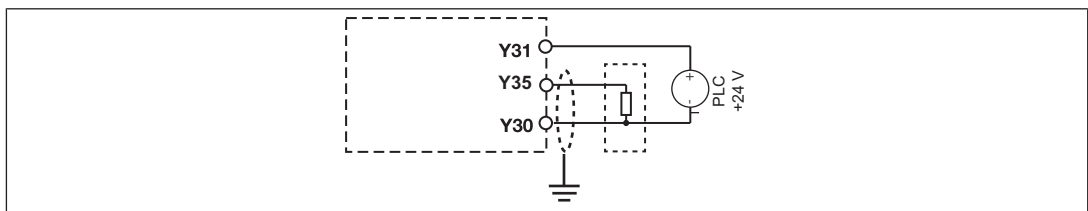

## 7.12 EMC-compliant wiring

### EMC-compliant wiring for connecting an encoder

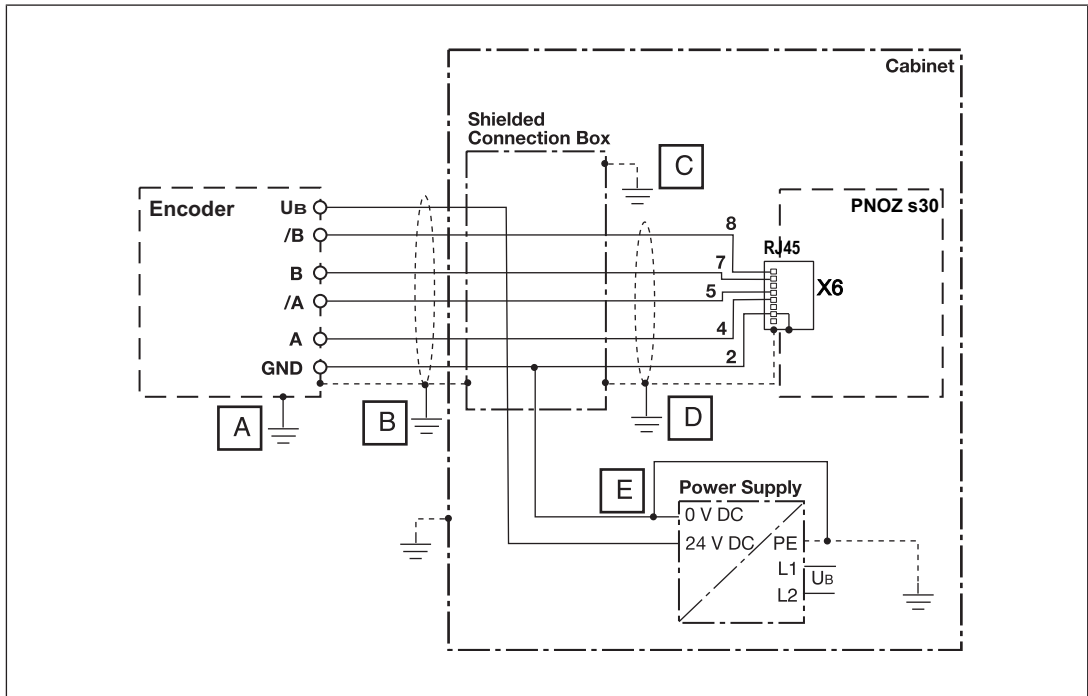

To avoid EMC interference we recommend that the shield on the sensor cables or the housing of the shielded junction box is only connected to earth at a single point:

**A or B or C or D or E**

Conductor loops outside the shield must be avoided.

If a shielded junction box is not used, the shield must run continuously from the sensor to the evaluation device.

EMC-compliant wiring for connecting an encoder with drive

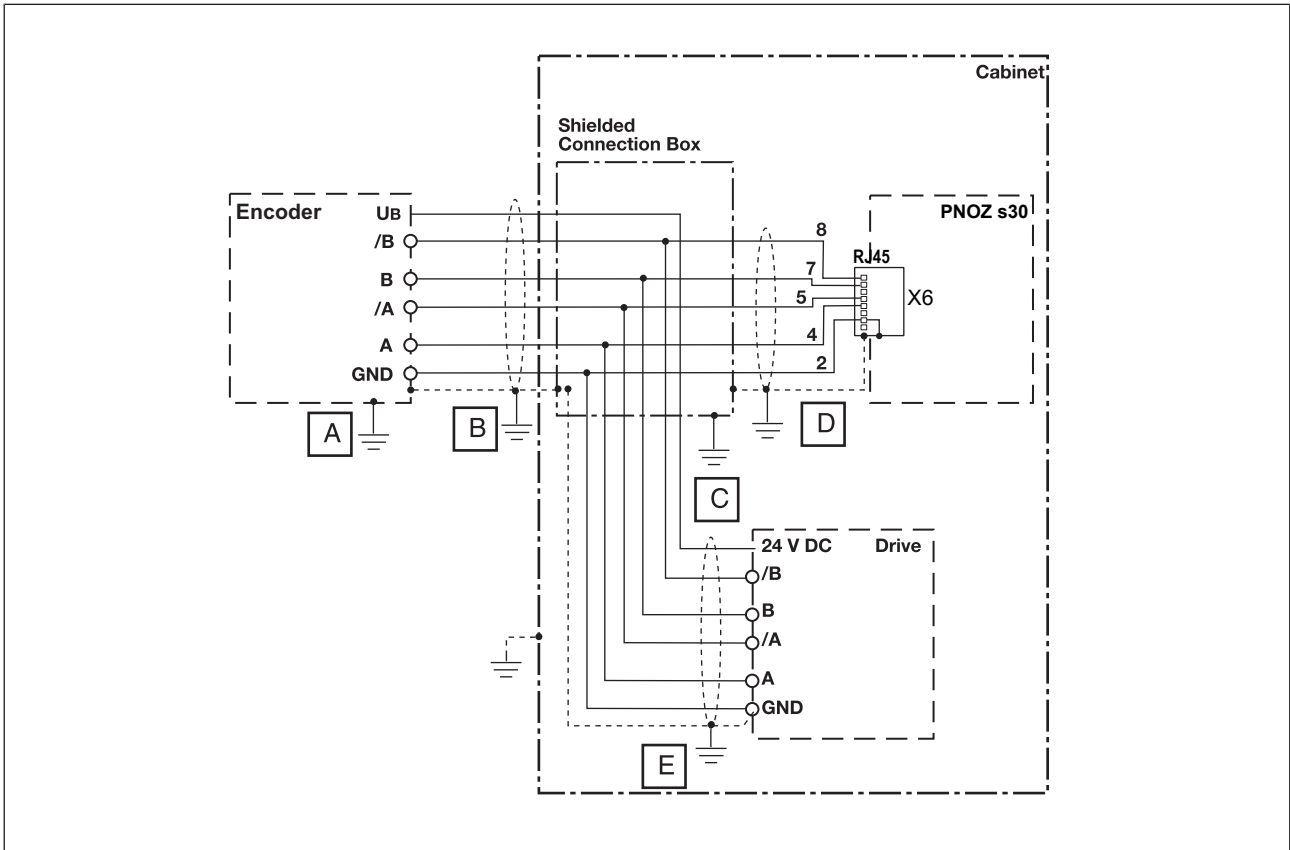

To avoid EMC interference we recommend that the shield on the sensor cables or the housing of the shielded junction box is only connected to earth at a single point:

**A or B or C or D or E**

Conductor loops outside the shield must be avoided.

If a shielded junction box is not used, the shield must run continuously from the sensor to the evaluation device.

### EMC-compliant wiring for connecting 2 proximity switches

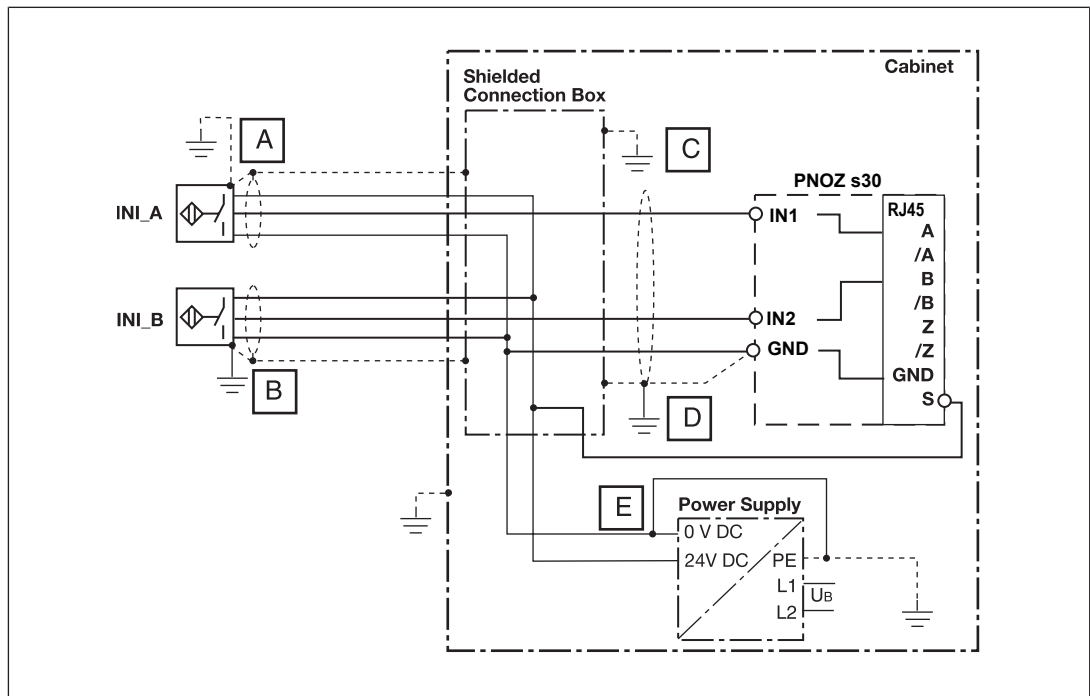

To avoid EMC interference we recommend that the shield on the sensor cables or the housing of the shielded junction box is only connected to earth at a single point:

**A or B or C or D or E**

Conductor loops outside the shield must be avoided.

If a shielded junction box is not used, the shield must run continuously from the sensor to the evaluation device.

**EMC-compliant wiring for connecting an encoder and a proximity switch**

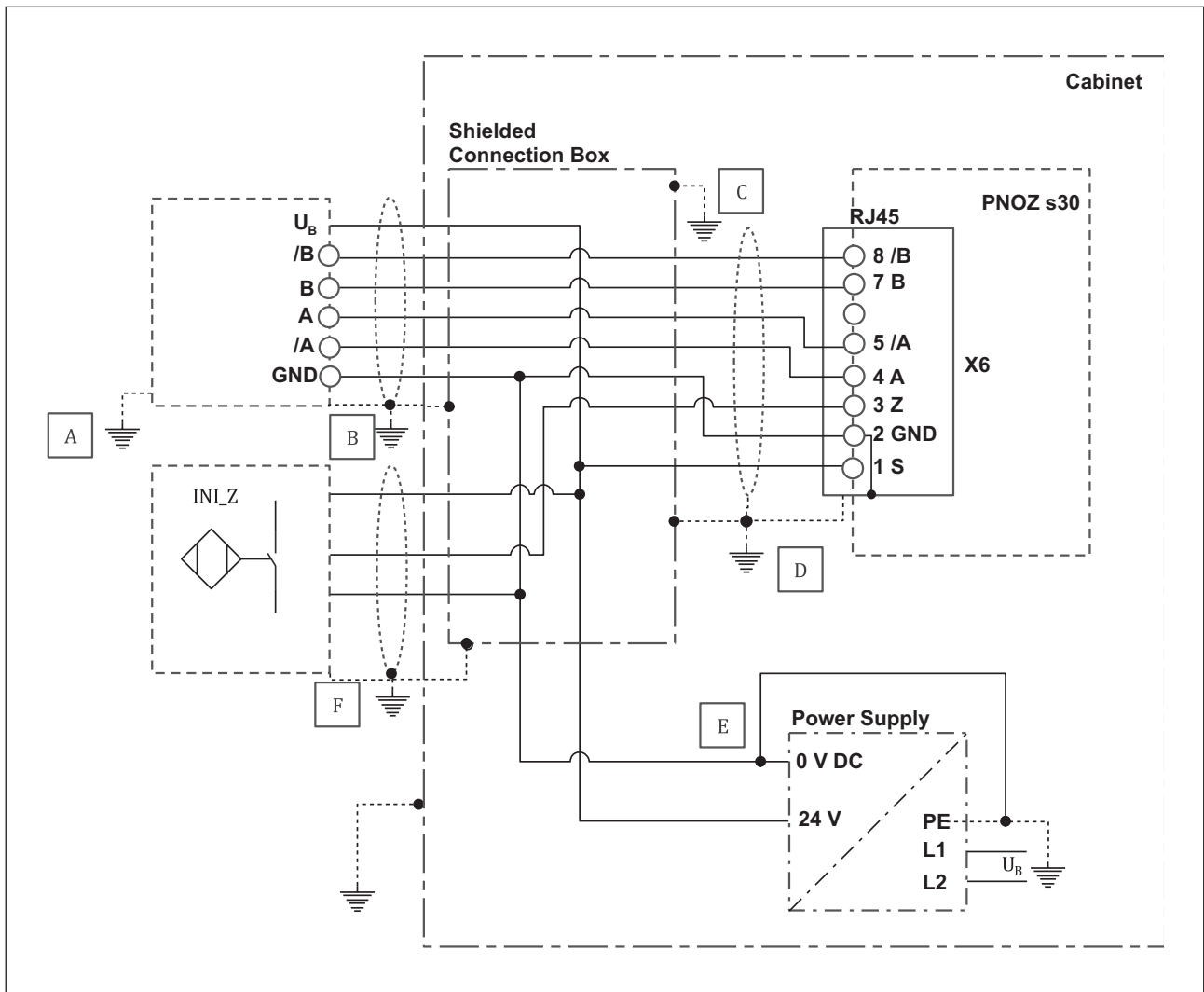

To avoid EMC interference we recommend that the shield on the sensor cables or the housing of the shielded connection box is connected to earth at a single point:

**A or B or C or D or E or F**

Conductor loops outside of the shield must be avoided.

If a shielded connection box is not used, the shield must run uninterrupted from the sensor to the evaluation device.

EMC-compliant wiring for connecting an encoder and an HTL encoder

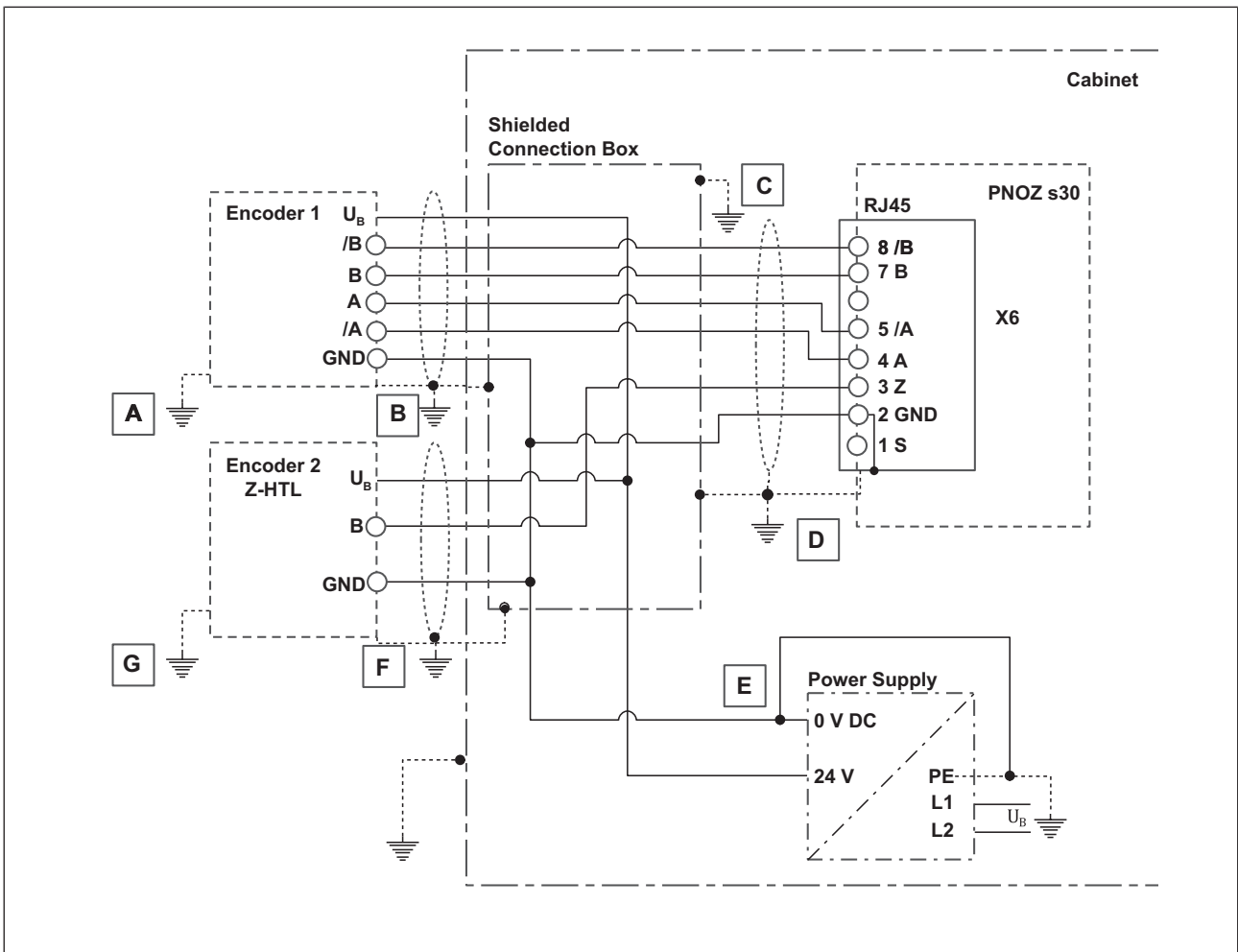

To avoid EMC interference we recommend that the shield on the sensor cables or the housing of the shielded connection box is connected to earth at a single point:

**A or B or C or D or E or F or G**

Conductor loops outside of the shield must be avoided.

If a shielded connection box is not used, the shield must run uninterrupted from the sensor to the evaluation device.

# 8 Display menu - Configuration

The menu settings are made on the unit's display via a rotary knob. You have the option to make the settings on the knob by hand or with a screwdriver. If you make the settings with a screwdriver, the knob can remain within the unit.

From device version 2.2 you have the opportunity to create the settings with the software-tool from Pilz (see [Create configuration in PNOZsigma Configurator](#) [📖 86]).

## 8.1 Create configuration overview

For a better overview, before entering the configuration values we recommend that they are entered in the attached form *PNOZ\_s30\_Config\_Overview*:

language	English	input device								global standstill (10 mHz-1 MHz)			
delay time start-up (0-600s)	Hysteresis (0-50%)	F1	F2	F3	F4	F5	F6	F7	F8	F9	input device settings (10 mHz-1 MHz)		
units		P0										f max (A/B)	
conversion		P1										f max (Z)	
mode select input		P2										ratio (0,0001-400.000:1)	
Sel 1 (Y10) Sel 2 (Y11) Sel 3 (Y12) Sel 4 (Y13)		P3										position monitoring (SOS-M)	
		P4										reset mode:	monitored (default)
		P5										position window width (1-24.900.000 Imp)	
		P6										Pos. 1	
delay time select input (0-30s)		P7										Pos. 2	
assign outputs (functions) delay time effect (outputs) delay time 0 - 30s (outputs) reset mode		P8										Pos. 3	
		P9										Pos. 4	
		P10										direction monitoring (SDI-M)	
		P11										Auto reset:	deactivated (default)
Synchronous start		P12										direction tolerance (max. wrong)	
output out logic		P13										direction left	
Ausgang Out 4 Analog fmax		P14										max. right	
	P15										direction right		
		Rel. 1 (13/14)	Rel. 2 (23/24)	Ext. 1	Ext. 2	Out 1 (Y32)	Out 2 (Y33)	Out 3 (Y34)	Out 4 (Y35)		max. left		
		monitoring \	monitoring \	monitoring \	monitoring \	monitoring \	monitoring \	monitoring \	monitoring \		name of configuration		
		deactivated	deactivated	deactivated	deactivated	deactivated	deactivated	deactivated	deactivated		CRC of configuration		
		normally on	normally on	normally on	normally on	normally on	normally on	normally on	normally on				

V.15-CS-TS-T.U.



## 8.2 Operate rotary knob

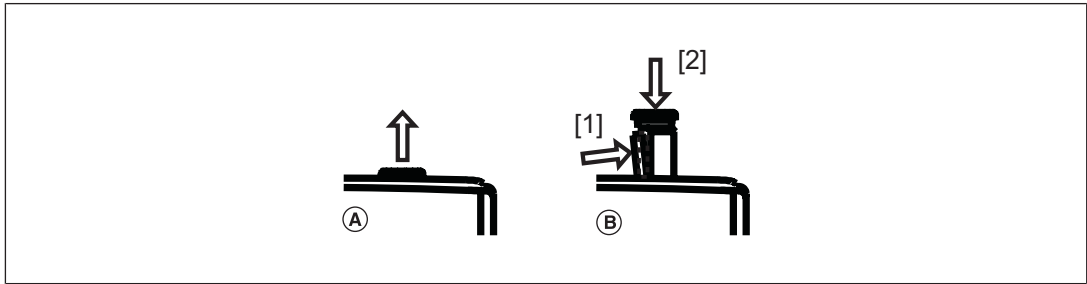

Knob :

- ▶ (A) pull out until it locks into position
- ▶ (B) release and push it back into the unit:
  - Press the bar on the side of the knob [1] towards the centre of the knob. This releases the knob.
  - Press the knob downwards [2] while keeping the bar pressed in

## 8.3 Configure Speed Monitor

The settings are made via the rotary knob, as follows:



Press knob

- ▶ Confirm selection/setting
- ▶ Switch to menu



Rotate knob

- ▶ Select menu level
- ▶ Set the parameter/numeric value

The speed with which you turn the knob affects the sequence of the menu and numeric values:

- ▶ Slowly: Units
- ▶ Quickly: Tens
- ▶ Very quickly:
  - Setting the numeric value: Hundreds
  - When switching the menu level: Jump to **ESCAPE**



#### NOTICE

Please note that all parameters are set to their default values on delivery. Please check all the safety-related parameters at least, and enter the values that correspond to your application.



#### INFORMATION

If no value is set or amended within 30 s of a menu action, the display reverts to the default display. The current setting remains unchanged. If the master password has been entered, this time increases to 5 minutes.

## 8.4 Password protection

The configuration is protected through passwords. There is a master password and a customer password.

Factory setting for both passwords: 0000

The password levels contain different authorisations:

#### ► Master password

Display: All settings

Edit: All settings

#### ► Customer password

Display: All settings

Edit:

- The customer password can be changed.
- The language can be changed.
- The settings can be reset to the factory settings.

#### ► No password

Edit:

- The language can be changed.
- The settings can be reset to the factory settings.

If the settings are reset to the factory settings, the passwords and the language will also be reset to the factory settings.

The passwords can be changed at any time in the menu.

Enter a 4-figure password.

## 8.5 Use chip card

The parameters that are set on a unit can be stored on the chip card. The data is stored along with a device identifier, the passwords, the name of the configuration and the check sum. We recommend that you **always** operate the unit with a chip card.

- If the parameters on a device have been changed due to an error, they can be restored using the backup copy on the chip card.

- ▶ If a unit requires maintenance or needs to be exchanged, the chip card can be used to download the parameters to another unit.



#### INFORMATION

If you operate the unit without a chip card, the "Fault" LED will light and the following message will appear once only: **Please Insert SIM Card!** If you change the parameters, the **Please Insert SIM Card!** message will re-appear.

The message disappears after 30 s or by pressing the rotary knob.

When the chip card is inside the unit:

- ▶ The chip card is checked to verify the device identifier, valid parameters, and ensure that the data is identical.
- ▶ Unit parameters are automatically saved to the chip card during operation. As a result, the chip card always contains a copy of the unit's current internal data. Exception: If you select **Write configuration to SIM: No**.

### 8.5.1

#### Insert chip card



#### NOTICE

The chip card contact is only guaranteed if the contact surface is clean and undamaged. For this reason please protect the chip card's contact surface from

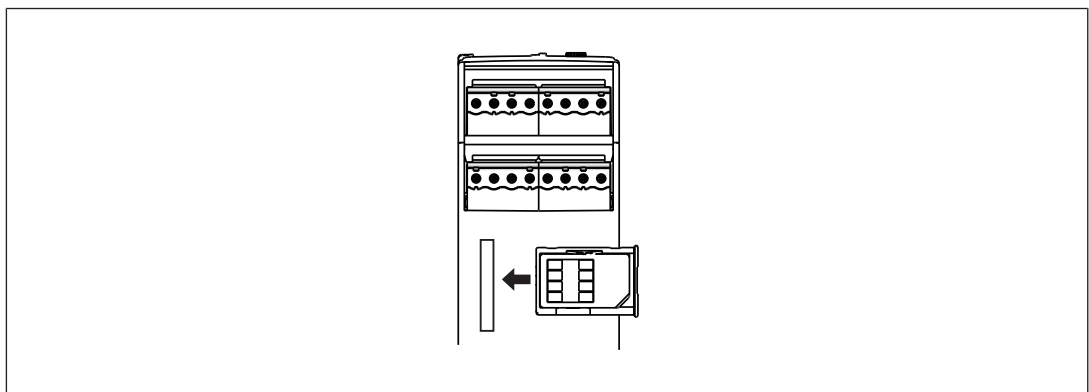

- Contamination
- Contact
- Mechanical impact, such as scratches.

Make sure that you do not bend the chip card as you insert it into the chip card slot.



### 8.5.2 Write data to chip card

If you are inserting a chip card which has not yet been written by a PNOZ s30, you have the option to:

	Insert chip card	1.		2.	Data is written to the chip card
<b>Please insert SIM Card!</b>	<b>Write configuration to SIM: No?</b>		<b>Write configuration to SIM: Yes?</b>		<b>Current menu</b>



Allow data to be written to the chip card

	Insert chip card	1.	Data is <b>not</b> written to the chip card
<b>Please insert SIM Card!</b>	<b>Write configuration to SIM: No?</b>		<b>Insert rewritable SIM Card!</b>

Do not allow data to be written to the chip card

### 8.5.3 Read data from chip card

If you are inserting a chip card which has not yet been written by a PNOZ s30, you have the option to:

	Insert chip card (data on chip card different from device)	1.		2.	Data is read into the unit
<b>Current menu</b>	<b>SIM: Name of the configuration (8 characters)</b> <b>CRC: 12345 (0 .. 65535)</b> <b>Load SIM: No?</b>		<b>SIM: Name of the configuration (8 characters)</b> <b>CRC: 12345 (0 .. 65535)</b> <b>Load SIM: Yes?</b>		<b>Current menu</b>

Allow data to be read from the chip card

Note:

After the chip card is loaded, all the outputs are switched off. The device must be restarted (switch off and on or software restart) to start up again.

	Insert chip card (Data on chip card different from device)	1.	Data is <b>not</b> read into the device, data is written to the chip card
<b>Current menu</b>	<b>SIM: Name of the configuration (8 characters)</b> <b>CRC: 12345 (0 .. 65535)</b> <b>Load SIM: No?</b>		<b>Write configuration to SIM: No?</b>  (for more details see "Write data to chip card")

Do not allow data to be read from the chip card

### 8.5.4 Transfer device parameters

You can transfer device parameters from one device to another using the chip card.



#### NOTICE

##### Please note:

If you transfer the device parameters from one device to a device with an older device version, then it cannot be guaranteed that the safety functions on the older device will behave in the same way. If device parameters are used that do not exist in that device version, then these parameters will not be recognised and, accordingly, this behaviour will be missing. From devices with Version 3.1, the transfer of device parameters to older devices is prevented.

To transfer the device parameters, proceed as follows:

Make a note of the configuration's CRC in the PNOZ s30. It is shown on the display in the **Information/ Configuration CRC** menu. This will be needed later, to check whether the correct configuration is saved on the device.

1. Remove the chip card containing the data from device 1.
2. Insert the chip card into device 2.
3. Confirm the message **Load SIM Yes?**
4. The data is downloaded.
5. To ensure that the configuration has been transferred correctly, check that the CRC for the configuration in the PNOZ s30 matches the configuration CRC you noted down.

### 8.5.5 Duplicate chip card



You can also create copies of a chip card and its data.

Follow the instructions below:

- ▶ Remove chip card containing the device data.
- ▶ Insert a new chip card into the device.
- ▶ Confirm the message **Write configuration to SIM Yes?**
- ▶ The new chip card is written.

With configurations from devices with an older device version, it may not be possible to create a compatible copy of the original chip card.

The message appears: **Config.Upgrade?**

		1.		2.	A configuration with identical function is generated, with a new CRC. This is not compatible with devices with an older version.
<b>Current menu</b>	<b>Config. upgrade: New CRC: 12345 (0...65535) No?</b>		<b>Config. upgrade: New CRC: 12345 (0...65535) Yes?</b>		<b>Current menu</b>

Update configuration

		2.	The configuration is not updated and is not written to the chip card.		
<b>Current menu</b>	<b>Config. upgrade: New CRC: 12345 (0...65535) No?</b>		<b>Insert rewritable SIM Card!</b>		

Do not update configuration

### 8.5.6 Compatibility with older device versions

Chip cards from devices with an older device version can be loaded.



The configuration CRC remains unchanged.

Note:

If you wish to ensure that the chip card can still be read in the device with an older device version, you must not change the configuration.

If you load and change an old configuration, then this configuration will be incompatible for devices with an older device version. You have the option to confirm or prevent this.

The message appears: **Upgrade SIM?**

		1.		2.	A new configuration, incompatible with older device versions, is written to the chip card
<b>Current menu</b>	<b>Upgrade SIM: New CRC: 12345 (0...65535) No?</b>		<b>Upgrade SIM: New CRC: 12345 (0...65535) Yes?</b>		<b>Current menu</b>

Allow the new configuration to be written to the chip card

		1.	The changed configuration exists only in the device memory. The chip card is locked for write access and all parameter changes are made only in the internal device memory. The current configuration can be stored on the chip card by inserting a new chip card.
<b>Current menu</b>	<b>Upgrade SIM:</b> <b>New CRC: 12345 (0... 65535)</b> <b>No?</b>		<b>Insert rewritable SIM Card!</b>

Do not allow the new configuration to be written to the chip card

If a chip card from a PNOZ s30 with an older device version was loaded and afterwards a new chip card was inserted, it may also be necessary to update the configuration. See [Duplicate chip card](#)  61].

## 8.5.7 Special cases and problem solving

### Outputs do not switch on correctly, although the same configuration works in another device

#### Prerequisite:

- ▶ Chip card from a PNOZ s30 <v3.0
- ▶ Device PNOZ s30 v3.0

#### Error

When loading the stated chip card into the device, under certain conditions the "Synchronous start" function can be activated unintentionally. In device versions <v3.0, this function is not available.

#### Solution

Deactivate the "Synchronous start" option on all outputs (see [Synchronous start](#)  24]).

### When a chip card is loaded, once the load process has been confirmed, the same question is asked again in a continuous loop

#### Prerequisite:

- ▶ Chip card from a PNOZ s30 <v3.0
- ▶ Device PNOZ s30 v3.0

#### Error

The contents of the chip card were already loaded into the device memory after the initial confirmation (see [Read data from chip card](#)  60]), but the CRC does not match the original CRC.

#### Solution

Check all the parameters to make sure that the configuration is functionally identical and make a note of the new CRC.

Then insert a new chip card and save the configuration on the chip card (see [Write data to chip card](#)  60]).

If you no longer need the chip card data from the older version, then this can also be used.

## 8.6 Save configuration with Software SmartCardCommander

You have the option to save a PNOZ s30 configuration from the chip card to your computer. The configuration can be saved on the computer and then downloaded to other chip cards.

To do this you will need the chip card reader **PNOZ Chip Card Reader** with the corresponding **SmartCardCommander** software. Both are available from Pilz as accessories, individually or as part of a set (see [Accessories](#) [📖 127]).

### Save PNOZ s30 configuration on the computer

1. Make a note of the configuration's CRC in the PNOZ s30. It is shown on the display in the **Information/ Configuration CRC** menu. This will be needed later to check whether the correct configuration is saved on the device.
2. Remove the chip card from the PNOZ s30 and insert it into the holder for the chip card reader.
3. Start the **SmartCardCommander** software.
4. Insert the holder containing the chip card into the chip card reader.
5. The **Memory Card** directory is displayed in a list under **Hardware** on the software interface of the **SmartCardCommander**.

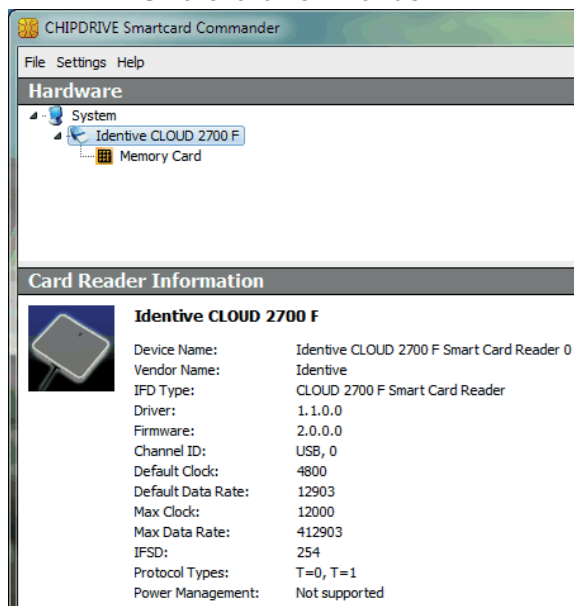

6. To read the data on the chip card, click on the **Memory Card** directory and then select **Read Data from Card**.
7. When **Data read successfully** is displayed on the software interface, the data can be saved as a hex file in any directory on the computer.
8. Make sure that the corresponding configuration CRC, which you noted down, is saved in the same directory.

### Download configuration from the computer to the PNOZ s30

1. Insert a chip card into the holder for the chip card reader and insert this into the chip card reader.



2. Start the **SmartCardCommander** software.
3. To write the chip card, select **Write Data to Card** and confirm with **Yes**.
4. Insert the chip card in the PNOZ s30 and proceed as described under [Read data from chip card](#) [ 60].
5. To ensure that the configuration has been transferred correctly, check that the CRC for the configuration in the PNOZ s30 matches the configuration CRC you noted down on the computer.



**CAUTION!**

With each transfer, you must check that the appropriate configuration for an application is transferred to a device!

## 8.7 Menu overview

The tables provide an overview of the menu settings.

### 8.7.1 Permanent display

If no settings are made, information regarding the configuration and current values are shown on the display.

You can change the permanent display on the display in the "Settings" menu.

### 8.7.2 Basic settings Ini pnp pnp

Settings for basic configuration 1

Level	Designation on the display	Description	Settings
1	<b>Basic Parameter</b> <b>Ini pnp pnp</b> Default: Load?	Select the default settings with which the basic configuration menu <b>Ini pnp pnp</b> is to be called:  -Load: The basic parameters are loaded. Then it switches to the basic menu <b>Ini pnp pnp</b> .  The basic parameters should always be loaded when commissioning for the first time.  - Edit?: The basic parameters are not loaded, i.e. all parameters are retained. The basic menu parameters can be changed within the permitted boundaries.  - Escape: Exits the basic menu.	
2	<b>Standstill</b> <b>Rel.1 Out 1</b> Default: 2.00Hz	Enter standstill frequency	100 mHz ... 10.0Hz
2	<b>v max</b> <b>Rel.2 Out 2</b> Default: 500Hz	Enter the max. permitted speed	10 mHz ... 3.00kHz

Other, pre-defined settings:

- ▶ **Encoder type**  
2 pnp type proximity switches
- ▶ **Parameter set/select input**  
P0, select inputs are ignored (Select inputs mode: "None")
- ▶ **Hysteresis**

Standstill and speed, 2 % each

▶ **Output assignment**

- Standstill: Relay output Rel.1 and semiconductor output Out 1
- Speed: Relay output Rel.2 and semiconductor output Out 2

▶ **Start mode**

- All outputs: Automatic start ("Automatic")

▶ **Switch delay**

None

▶ **Max. encoder frequency**

3.5kHz

### 8.7.3 Basic settings for the rotary encoder

Settings for basic configuration 2

Level	Designation on the display	Description	Settings
1	<b>Basic Parameter Encoder:</b> Default: Load?	Select the default settings with which the basic configuration menu " <b>Rotary encoder:</b> " is to be called:  - Load: The basic parameters are loaded. Then it switches to the basic menu " <b>Rotary encoder:</b> ".  The basic parameters should always be loaded when commissioning for the first time.  - Edit: The basic parameters are not loaded, i.e. all parameters are retained. The basic menu parameters can be changed within the permitted boundaries.  -Escape: Exits the basic menu.	
2	<b>Encoder</b> Default: TTL differential	Select rotary encoder type	-TTL differential (A, /A, B, /B) -TTL single ended (A, B) -HTL differential (A, /A, B, /B) -HTL single ended (A, B) -sin/cos 1 Vss (A, /A, B, /B) -Hiperface (A, /A, B, /B)
2	<b>Standstill Rel.1 Out 1</b> Default: 100 Hz	Enter standstill frequency	10 mHz to 1.00 kHz

Level	Designation on the display	Description	Settings
2	<b>v max</b> <b>Rel.2 Out 2</b> Default: 5.00 kHz	Enter the max. permitted speed	10 mHz to 1.00 MHz

Other, pre-defined settings:

▶ **Switch functions**

– **Direction (F3)**

Left direction

Tolerance for wrong direction = 10 pulses

– **Direction (F4)**

Right direction

Tolerance for wrong direction = 10 pulses

▶ **Parameter set/select input**

P0, select inputs are ignored (Select inputs mode: "None ")

▶ **Hysteresis**

Standstill and speed, 2 % each

▶ **Output assignment**

– Standstill: Relay output Rel. 1 and semiconductor output Out 1

– Speed: Relay output Rel. 2 and semiconductor output Out 2

– Left direction: External output Ext. 1 and semiconductor output Out 3

– Right direction: External output Ext. 2 and semiconductor output Out 4

▶ **Start mode**

– All outputs: Automatic start ("Automatic")

▶ **Switch delay**

None

▶ **Max. encoder frequency**

1 MHz

### 8.7.4 Settings

Level	Name on the display	Description	Settings
1	<b>Permanent Display</b> Default: Std Min : Sek (system time) v (current speed of track AB) Position	Permanent display Current values and information regarding configuration are displayed. You can change the permanent display on the display	<b>Display combinations:</b> ▶ vz (current speed of track Z) ▶ v (current speed of track AB) ▶ Position  ▶ Switch functions 1 ... 9: F1 ... F9 ▶ v (current speed of track AB) ▶ Position ▶ Line 1/2: F1/F2, F3/F2, F5/F4, F7/F6 or F9/F8 (parameters selected via select inputs). ▶ v (current speed of track AB)  ▶ Std Min : Sek (system time) ▶ v (current speed of track AB) ▶ Position
1	<b>Displ. Units</b> <b>Speed: Dist: Pos.:</b> Default: Hz Imp	Select unit of speed and unit of distance (position).	<b>Speed: (speed) - Pos. (distance/position)</b> ▶ Hz Imp (pulse) ▶ Hz Edg (edge) ▶ m/s m ▶ m/min m ▶ m/h m ▶ rps rot ▶ rpm rot
1	<b>Conversion</b> Default: 1 Hz= 1 Imp/s	Unit conversion. Enter ratio of unit to pulses.	Display ▶ 1 Hz= 1 Imp/s ▶ 1 Hz = 4 Edg/s ▶ 1 m = x Imp (x = 1 ... 10,000,000 Imp) ▶ 1 rot = x Imp (x = 1 ... 10,000,000 Imp)
1	<b>Encoder Settings</b>	Create encoder configuration for tracks A, /A, B, /B, Z, /Z, S	

Level	Name on the display	Description	Settings
2	<b>Encoder</b> Default: Undefined	Select pre-defined encoder types for the tracks A, B and Z: Proximity switch Encoder <ul style="list-style-type: none"> <li>▶ with and without inverted signals</li> <li>▶ with or without Z-Index (0-Index)</li> <li>▶ with proximity switch at track Z</li> </ul> Note: If "Undefined" is selected, then an error message is displayed when you confirm the menu	<b>No encoder selected:</b> <ul style="list-style-type: none"> <li>▶ Undefined</li> </ul> <b>Proximity switch (Ini):</b> <ul style="list-style-type: none"> <li>▶ Initiator A: pnp B: pnp</li> <li>▶ Initiator A: npn B: pnp</li> <li>▶ Initiator A: pnp B: npn</li> <li>▶ Initiator A: npn B: npn</li> <li>▶ Initiator A/B: pnp r.D. (with reduced diagnostics)</li> </ul> <b>Encoder:</b> <ul style="list-style-type: none"> <li>▶ <b>TTL</b> <ul style="list-style-type: none"> <li>– TTL differential (A, /A, B, /B)</li> <li>– TTL single ended (A, B)</li> </ul> </li> <li>▶ <b>TTL with Z-Index</b> <ul style="list-style-type: none"> <li>▶ TTL diff. Z index (A, /A, B, /B, Z, /Z)</li> <li>▶ TTL single Z index (A, B, Z)</li> </ul> </li> <li>▶ <b>HTL</b> <ul style="list-style-type: none"> <li>– HTL differential (A, /A, B, /B)</li> <li>– HTL single ended (A, B)</li> </ul> </li> <li>▶ <b>HTL with Z-Index</b> <ul style="list-style-type: none"> <li>HTL diff. Z index (A, /A, B, /B, Z, /Z)</li> <li>HTL single Z index (A, B, Z)</li> </ul> </li> <li>▶ <b>Sin/Cos 1 Vss</b> <ul style="list-style-type: none"> <li>– sin/cos 1 Vss (A, /A, B, /B)</li> </ul> </li> <li>▶ <b>Sin/Cos 1 Vss with Z-Index</b> <ul style="list-style-type: none"> <li>– sin/cos 1 Vss Z Index (A, /A, B, /B, Z, /Z)</li> </ul> </li> <li>▶ <b>Hiperface</b> <ul style="list-style-type: none"> <li>– Hiperface (A, /A, B, /B)</li> </ul> </li> </ul>

Level	Name on the display	Description	Settings
			<p><b>Rotary encoder + pnp proximity switch</b></p> <p>▶ <b>TTL + pnp proximity switch *</b></p> <ul style="list-style-type: none"> <li>– TTL diff. (A, /A, B, /B), Z Freq Inipnp (Z)</li> <li>– TTL single (A, B), Z Freq Inipnp (Z)</li> </ul> <p>▶ <b>HTL + pnp proximity switch *</b></p> <ul style="list-style-type: none"> <li>– HTL diff. (A, /A, B, /B), Z Freq Inipnp (Z)</li> <li>– HTL single (A, B), Z Freq Inipnp (Z)</li> </ul> <p>▶ <b>sin/cos 1 Vss + pnp proximity switch *</b></p> <ul style="list-style-type: none"> <li>– sin/cos 1 Vss (A, /A, B, /B), Z Freq Inipnp (Z)</li> </ul> <p>▶ <b>Hiperface + pnp proximity switch *</b></p> <ul style="list-style-type: none"> <li>– Hiperface (A, /A, B, /B), Z Freq Inipnp (Z)</li> </ul> <p>* Alternatively, a track from an HTL encoder can also be used instead of a pnp proximity switch</p> <p>The configuration is the same as with the pnp proximity switch as Z-frequency monitoring.</p>
2	<b>Track AB</b>	Settings for tracks A and B	
3	<b>AB Direction</b> Default: Normal	Select direction for tracks A and B Information: This function is used to display a forward movement as positive linear/rotational speed, irrespective of the installation of the rotary encoder.	<p>▶ Normal</p> <p>▶ Inverted</p>
3	<b>Track AB fmax</b> Default: 10 mHz	Enter max. frequency of the encoder on tracks A and B Important: The frequency must be less than or equal to the max. encoder frequency specified in the encoder's data sheet and less than the max. speed of the monitored drive.	10 mHz ... 1.00 MHz

Level	Name on the display	Description	Settings
3	Restart Default: <b>Track AB Tol</b>	Enter tolerance time for invalid signal level on tracks A and B.  On encoder types with Z-index, this tolerance time is also effective on track Z.	▶ <b>Track AB Tol</b> ▶ 50 ms ... 2500 ms
2	<b>Track Z</b>	Settings for track Z	
3	<b>Track Z fmax</b> Default: 10 mHz	Enter max. frequency of the encoder on track Z  Important:  The frequency must be less than the max. encoder frequency specified in the encoder's data sheet	10 mHz ... 1.00 MHz
2	<b>AB/fZ Ratio</b> Default: 1,0000 : 1	<b>Only required with 2-encoder diagnostics/broken shearpin monitoring or rotary encoder with Z-Index .</b>  ▶ <b>2-encoder diagnostics and broken shearpin monitoring</b> Enter the ratio of the frequency on tracks AB "fAB" to the frequency on track Z "fZ". Used for frequency monitoring on track Z <b>Information</b> Calculation of the ratio of the frequencies: Enter permanent display: "vz: v: Position:" Switch on drive Read vz and v Divide v/vz Enter result as fAB to fZ ratio  ▶ <b>Rotary encoder with Z-Index</b> The value <b>fAB/fZ Ratio</b> corresponds to the number of lines (resolution) on the encoder you are using (lines/revolution).  Used to check the Z-index.	0.0001 ... 400,000 : 1



Level	Name on the display	Description	Settings
3	Off Default: <b>Track AB Tol</b>	Enter tolerance time for invalid signal level on track Z.  This tolerance time is only effective on encoder types "rotary encoder + pnp proximity switch".	▶ <b>Track AB Tol</b> ▶ 50 ms ... 2500 ms
2	<b>Track S</b>	Settings for track S (error track)	
3	<b>Track S</b> Default: Not used	Use of track S: -Not used (track S is not used) -Evaluation (track S is used)	▶ Not used ▶ Evaluation
3	<b>Track S Umax</b> Default: 6.0 V	Enter max. voltage at track S. If the voltage is > Umax, an error is displayed and the outputs are switched off.	0.0 V ... 30.0 V
3	<b>Track S Umin</b> Default: 2.0 V	Enter min. voltage at track S. If the voltage is < Umin, an error is displayed and the outputs are switched off.	0.0 V ... 30.0 V
3	<b>Track Z Tol.</b> Default: <b>Track AB Tol</b>	Enter tolerance time for invalid signal level on track S.	▶ <b>Track AB Tol</b> ▶ 50 ms ... 2500 ms
1	<b>Delay Time Startup</b> Default: 0.00 s	Select start-up delay (When the device is restarted, the start-up phase of the PNOZ s30 is extended by this time. The encoder signals are not evaluated until after the start-up phase.)	0 ... 600 s
1	<b>Function Parameter</b>	Select function parameter	





Level	Name on the display	Description	Settings
2	<b>Standstill v<sub>max</sub>:</b> Default: 2.00Hz	Select standstill frequency  Validation cut-off frequency As implausible signals may arise due to edge jitter on the encoders around the standstill position, a validation cut-off frequency must be configured for "proximity switch" encoder types (without rotary encoder) (edge jitter is caused by the position control of the drive frequency converter or by external interference signals).  If the value of the validation cut-off frequency falls below the configured value, the plausibility check of the sensors will no longer be run.	10 mHz ... 1.00 MHz  or the corresponding value in the selected unit
2	<b>(F1 ... F9) Parameter</b>	Enter parameter for the switch functions F1 ... F9	
3	<b>(F1 ... F9) (P0 ... P15) Parameter</b> Default: 10 mHz	For each switch function F1 ... F9 up to 16 parameters P0 ... P15 can each be configured.	
4	<b>(F1 ... F9) (P0 ... P15) Teach v<sub>max</sub>:</b> Display: Current linear/rotational speed	The current linear/rotational speed is displayed and can be adopted as a limit value.	
4	<b>(F1 ... F9) (P0 ... P15) v<sub>max</sub>: Standstill</b>	<b>"Standstill"</b> is displayed and can be adopted  Information:  The standstill frequency is selected globally in the menu <b>"Standstill v<sub>max</sub>:"</b>  (see above)	

Level	Name on the display	Description	Settings
4	(F1 ... F9) (P0 ... P15) vmax: 2.00 kHz	Select linear/rotational speed limit	10 mHz ... 1.00 MHz or the corresponding value in the selected unit
4	(F1 ... F9) (P0 ... P15) Function Position(1 ... 4)	Select position monitoring 1 ... 4	
4	(F1 ... F9) (P0 ... P15) Function (Direct. Left, Direct. Right)	Select left-hand or right-hand direction monitoring	
4	(F1 ... F9) (P0 ... P15) Fixed value (On/Off)	Select static value On or Off	
2	Track S Tol.	A special function can be configured for each parameter set (except in select mode "None")	
3	(P0 ... P15) Default: Special Functions	A special function can be configured for each parameter set (except in select mode "None") The special functions are activated via the select inputs.	<ul style="list-style-type: none"> <li>▶ <b>Special Functions</b></li> <li>▶ none</li> </ul> <p>With this setting, please also refer to the guidelines stated under <a href="#">2 encoder diagnostics / broken shearpin monitoring</a> [ 21]</p> <ul style="list-style-type: none"> <li>▶ No2-Enc-Diag.</li> <li>▶ ErrorAcknowledge</li> </ul>
1	Assign Outputs	Assign functions to outputs	

Level	Name on the display	Description	Settings
2	<b>Output (Rel.1 ... Out 4)</b> Default: 0: Off	Each output can be assigned a switch function, an area or a logic operation. Each output can also be used as an error output or can be switched off. Outputs: Rel.1: Relay output 1 Rel.2: Relay output 2 Ext.1: External output 1 Ext.2: External output 2 Out 1 ... Out 4: Semiconductor outputs 1 ... 4 Out 4: Can also be configured as an analogue output	0: Off <b>Switch function (1 .. 9)</b> 1 ... 9: F1 ... F9 <b>Range</b> 10: F2-F3 11: F4-F5 12: F6-F7 13: F8-F9 <b>Error output</b> 14: error <b>Logic operations (Log. Conn)</b> 15: F2 $\wedge$ F3 16: F4 $\wedge$ F5 17: F1 $\wedge$ F6-F7 18: F1 $\wedge$ F8-F9 19: F6 $\vee$ F7 20: F8 $\vee$ F9 21: F1 $\vee$ F2-F3 22: F1 $\vee$ F4-F5 <b>Analogue output (Analog)</b> 23: 0 - 20 mA 24: 4 - 20 mA
1	<b>Start mode</b>	Select start behaviour	
2	<b>Start mode (Rel.1 ... Out 4)</b> Default: Monitored /	Select start mode for each output separately Automatic: Automatic start Monitored /: Monitored start with rising edge at S34 Monitored \: Monitored start with falling edge at S34	▶ Automatic ▶ Monitored / ▶ Monitored \

### 8.7.5 Advanced settings

Level	Menu designation	Description	Settings
1	<b>Positions Parameters</b>	Settings for position monitoring functions	
2	<b>Position (1 ... 4)</b> Start mode Default: Monitored /	Enter start type for position monitoring	<ul style="list-style-type: none"> <li>▶ Monitored /</li> <li>▶ Automatic</li> </ul>
2	<b>Position (1 ... 4)</b> <b>Window width</b> Default: 1 pulse	Enter width of position window for position monitoring functions 1 ... 4	1 ... 24,900,000 pulses or the corresponding value in the selected unit
1	<b>Direction Parameter</b>	Settings for direction monitoring	
2	<b>Direction Autoreset</b> Default: deactivated	Activate/deactivate automatic reset of the direction monitoring	<ul style="list-style-type: none"> <li>▶ deactivated</li> <li>▶ activated</li> </ul>
2	<b>(Direct. Left max. right, Direct. Right max. left)</b> Default: 0 pulses	Enter max. tolerated number of pulses (or Edg, m, rot) in the wrong direction.	1 ... 24,900,000 pulses or the corresponding value in the selected unit
1	<b>Mode Select Input</b> Default: None	Setting for using the select inputs	<ul style="list-style-type: none"> <li>▶ All 16</li> <li>▶ 1 from 4</li> <li>▶ None</li> </ul>
1	<b>Delay Select Input</b> Default: tdl: 0 ms	Enter delay time of the select inputs Y10 – Y13 Info: The states of the select inputs are only adopted if they were unchanged during the set time.	0 ... 30.0 s
1	<b>2-Encoder diagnostics</b>	Comparison of $f_{AB}$ and $f_Z$	
2	<b>Activation speed</b>	On both encoders, speed $v_{ABZ}$ from which the check is carried out.	$v_{ABZ} = 0$ (check is always carried out) $v_{ABZ} = 10 \text{ MHz} \dots 1 \text{ MHz}$
1	<b>Frequency filter</b> Default: Off	Filtering of the measured speed	<ul style="list-style-type: none"> <li>▶ Off</li> <li>▶ Fast</li> <li>▶ Moderate</li> <li>▶ Slow</li> </ul>

Level	Menu designation	Description	Settings
1	<b>Function Hysteresis</b>		
2	<b>(F1 ... F9) Function Hysteresis</b> Default: 1 %	Enter hysteresis for the switch functions F1 ... F9 (not effective with position and direction monitoring)	0 ... 50 %
1	<b>Output Delay</b>	Setting for the delay effect and delay time for the outputs	
2	<b>Delay Output (Rel.1 ... Out 4)</b> Default: On 0 ms (display only)	Setting for the delay time effect and delay time for the respective output	
3	<b>Delay Effect (Rel.1 ... Out 4)</b> Default: 	Enter whether the delay time is to be activated when switching on, switching off, or switching on and off.	<ul style="list-style-type: none"> <li>▶ Switch-on delay retriggerable </li> <li>▶ Switch-off delay retriggerable </li> <li>▶ Switch-on switch-off delay retriggerable </li> <li>▶ Switch-off delay not retriggerable </li> </ul>
3	<b>Delay Time (Rel.1 ... Out 4)</b> Default: tdO: 0 ms	Select delay time for the respective output	0 ... 30.0 s
1	<b>Output Out Logic</b>	Setting for the switching direction of the semiconductor outputs	
2	<b>output (Out 1 ... Out 4) Logic</b> Default: N/O contact	Select the switching direction of the semiconductor outputs Out 1 ... Select Out 4: N/O contact (normally energised mode) N/C contact (normally de-energised mode)	<ul style="list-style-type: none"> <li>▶ N/O contact</li> <li>▶ N/C contact</li> </ul>
1	<b>Outputs Synchronous start</b>	Setting for synchronous start	

Level	Menu designation	Description	Settings
2	<b>Sync. Start</b> (Rel. 1 ... Out 4) Default: deactivated	Set whether outputs are to be started synchronously.	<ul style="list-style-type: none"> <li>▶ deactivated</li> <li>▶ activated</li> </ul>
1	Outputs Out 4 Analog	Scaling of analogue input	
1	<b>Out 4 Analog</b> f at 20 mA Default: 1MHz	Enter maximum frequency $f_{\max}$ for 20mA	Frequency $f_{\max}$ : 10 mHz ... 1 MHz
1	<b>Name of Configuration</b> Default: Default	Enter name of the configuration The name may be a max. of 8 characters in length It is stored on the chip card	.....
1	<b>Password Settings</b>	Change passwords Note: In the "Default Settings" menu, the passwords are reset to the default setting: 00000.	
2	<b>Master PW</b>	Change master password	0000 ... 9999
2	<b>Customer PW</b>	Change customer password	0000 ... 9999
2	<b>Language</b> Default: English	Select menu language	<ul style="list-style-type: none"> <li>▶ English</li> <li>▶ German</li> <li>▶ French</li> </ul>
1	<b>Default Settings</b>	Select whether the parameters are to be reset to the default settings Yes: All parameters are reset to the default values. The language is set to English and all passwords are set to 0000.	<ul style="list-style-type: none"> <li>▶ Escape</li> <li>▶ Yes</li> </ul>

### 8.7.6 Information

Level	Menu designation	Description	Display/Settings
1	<b>System Time</b>	Time that the device is switched on	xxx.xxx h xx min xx s
1	<b>Max. Speed Track AB</b>	Max. measured linear/rotational speed at tracks A and B The value can be reset to 0	0 ... 1 MHz or the corresponding value in the set unit Reset: Reset: - Yes? - No
1	<b>Max. Speed Track Z</b>	Max. measured linear/rotational speed at track Z The value can be reset to 0	0 ... 1 MHz or the corresponding value in the set unit Reset: Reset: - Yes? - No?
1	<b>Relay (Ctrl, 1, 2) Cycles</b>	Information: Total number of relay operations Relay Ctrl (root relay, common 2nd shutdown route) Relay 1 (relay output 1: 11-12, 13-14) Relay 2 (relay output 2: 21-22, 23-24)	0 ... 6,000,000 x, > 6,000,000 x
1	<b>CRC of Configuration</b>	Check sum of configuration parameters	0 ... 65535



Level	Menu designation	Description	Display/Settings
1	<b>Error Stack Entries</b>	<p>Error stack entries</p> <p>Up to 20 error stack entries are displayed</p> <p>See chapter <a href="#">Error stack entries</a> [90]</p> <p>Further information can be displayed by pressing the rotary knob.</p>	<p>Repairable error:</p> <p>Level 2:</p> <p>1st line: Seq. No. "<b>Err.:</b>", error number</p> <p>2nd + 3rd line: Plain text to describe error for the user</p> <p>Level 3:</p> <p>1st line: Seq. No. "<b>Repairable</b>"</p> <p>2nd line: "<b>System Time</b>"</p> <p>3rd line: System time when the error occurred</p> <p>Level 4:</p> <p>Information for Pilz Service</p> <p>System error:</p> <p>Level 2:</p> <p>1st line: Seq. No. "<b>Err.:</b>", error number</p> <p>2nd line: "<b>System Error</b>"</p> <p>3rd line: System time when the error occurred</p> <p>Level 3:</p> <p>Information for Pilz Service</p>
1	<b>Safe Error Stack Entries?</b>	The error list can be saved to the chip card.	
2	<b>Safe Error Stack Entries:</b> 100%	Appears when the error list is saved	
1	<b>Input Module SW Version</b> Va.b	For internal purposes only	
1	<b>Main Unit SW Version</b> Va.b	For internal purposes only	

### 8.7.7 Restart

Level	Menu designation	Description	Settings
1	ErrorAcknowledge	Restart PNOZ s30	

### 8.7.8 Menu messages

Level	Menu designation	Description	Display/Settings
-	<b>Actual error messages</b>	<p>Up to 8 errors are displayed.</p> <p>Recoverable errors: Level 2, 3 and 4 (user-recoverable)</p> <p>System error: Level 2 and 3 (internal error, information for Pilz Service).</p> <p>The error messages can be hidden with "Escape".</p>	<p>Repairable error:</p> <p>Level 2: 1st line: Seq. No. "<b>Err.:</b>", error number 2nd + 3rd line: Plain text to describe error for the user</p> <p>Level 3: 1st line: Seq. No. "<b>Repairable</b>" 2nd line: "<b>System Time</b>" 3rd line: System time when the error occurred</p> <p>Level 4: Information for Pilz Service</p> <p>System error:</p> <p>Level 2: 1st line: Seq. No. "<b>Err.:</b>", error number 2nd line: "<b>System Error</b>" 3rd line: System time when the error occurred</p> <p>Level 3: Information for Pilz Service</p>
-	<b>Error Faulty Signal: A/A B/B Z/Z</b>	<p>Error message: Incorrect signal at one or more tracks.</p> <p>The message</p> <ul style="list-style-type: none"> <li>- is continually updated.</li> <li>- can be ignored temporarily.</li> </ul>	
-	<b>AB frequency deviation</b>	<p>Error message: Frequency difference between the proximity switches on tracks A and B</p> <p>The message</p> <ul style="list-style-type: none"> <li>- is continually updated</li> <li>- can be ignored temporarily</li> </ul>	
-	<b>Chip card messages</b>		

Level	Menu designation	Description	Display/Settings
-	<b>Please insert SIM Card!</b>	Appears when the device is operated without a chip card or when a defective chip card is inserted, appears again when parameters are changed.  Info:  The message disappears after 30 s or by pressing the rotary knob	
-	<b>Please insert writable SIM Card!</b>	Appears when the answer to "Load SIM" and "Write Configuration to SIM:" is "No"	
-	SIM: ..... CRC: ..... <b>Load SIM</b>  Default: No?	Appears when device detects a chip card with a valid configuration.  -> Select whether the chip card data is to be transferred to the device.	- No? - Yes?
-	<b>Write Configuration to SIM:</b>  Default: No?	Appears  - When a chip card has been used that does not yet contain data  - When a chip card has been used that does not contain any valid data  - When <b>Load SIM</b> No was selected  -> Select whether the data is to be saved to the chip card.	- No? - Yes?
-	<b>Upgrade config?</b> <b>New CRC:</b>  Default: No?	Appears when a configuration from devices with an older version are to be copied (see <a href="#">Duplicate chip card [61]</a> ).	
-	<b>Upgrade SIM?</b> <b>New CRC:</b>  Default: No?	Appears when an old configuration has been loaded and changed (see <a href="#">Compatibility with older device versions [62]</a> ).	

Level	Menu designation	Description	Display/Settings
-	<b>SIM loaded! Internal CRC changes!</b>	Appears when the data has been transferred to the device and therefore the CRC has changed.	
-	<b>Password mes- sages:</b>		
-	<b>Master PW:</b> Default: 0000	-> Enter master password <b>Password:</b>	0000 ... 9999
-	<b>Password:</b> Default: 0000	-> Enter customer password	0000 ... 9999
<b>1</b>	<b>System Time</b>	Time that the device is switched on	xxx.xxx h xx min xx s

## 8.8 Example: Configure basic configuration 2

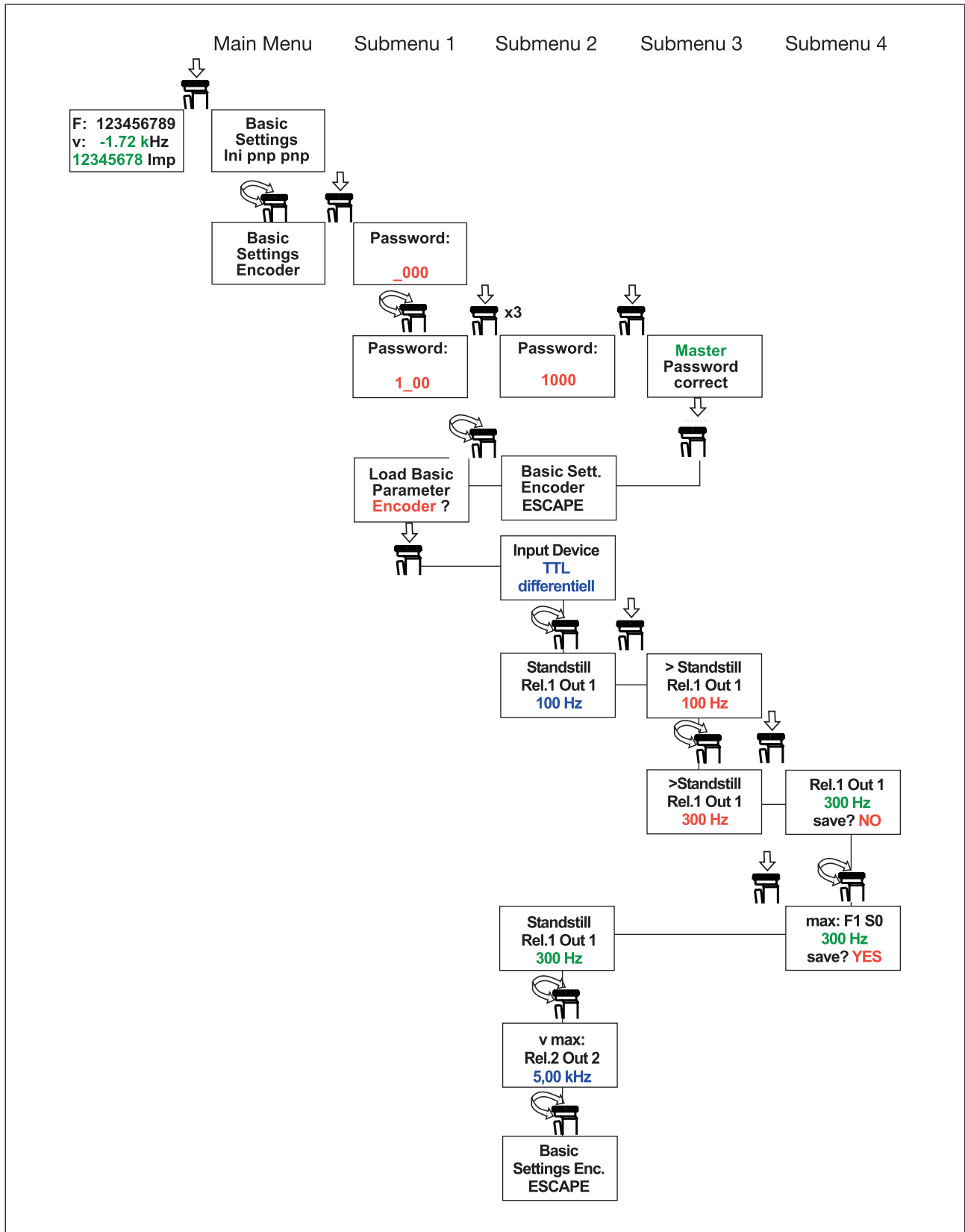

## 9 Create configuration in PNOZsigma Configurator

For devices PNOZ s30 from Version 2.2 you have the opportunity to perform the configuration in the software tool PNOZsigma Configurator.

The PNOZsigma Configurator can be downloaded from the Internet in the download area of the Pilz website.

With the PNOZsigma Configurator you can configure all the functions that are described in the function description.

In Version 1.0. and 1.1 of the PNOZsigma Configurator the configuration is downloaded via the chip card reader **PNOZ Chip Card Reader**. From Version 1.2 of PNOZsigma Configurator you can perform the download alternatively via the cable **PNOZ s30 USB-configuration-cable**. Both are available from Pilz as [accessories](#) [ 127].

### 9.1 Download project from the PNOZsigma Configurator to the PNOZ s30



#### CAUTION!



Perform a commissioning test every time that you download a project to the PNOZ s30.





#### CAUTION!

With each transfer, you must check that the appropriate configuration for an application is transferred to a device!



#### Download project via the chip card from the PNOZsigma Configurator to the PNOZ s30

1. Open the PNOZsigma Configurator and create your configuration.
2. Remove the chip card from the PNOZ s30 and insert it into the holder for the chip card reader.
3. In the PNOZsigma Configurator, click on the project to be downloaded in the **Project Overview** and click on the  button in the project to download the configuration to the chip card.
4. When the download is complete, remove the chip card from the chip card reader and insert it into the PNOZ s30 again.
5. To save the configuration on the PNOZ s30 follow the instructions given in chapter [Read data from chip card](#) [ 60].
6. To ensure that the configuration has been transferred correctly, check that the Configuration CRC in the PNOZ s30 matches the CRC that is shown in the title bar in the PNOZsigma Configurator.

**Download project via cable from the PNOZsigma Configurator to the PNOZ s30**

1. Connect the PNOZ s30 with a free USB interface of your computer. To do this, use the cable **PNOZ s30 USB-configuration-cable** (order no.: 750 040), which is available at Pilz as an [accessory](#)  127].
2. In the PNOZsigma Configurator, click on the project to be downloaded in the **Project Overview** and click on the  button in the project to download the configuration to the PNOZ s30.  
**Please note:** Existing data on the PNOZ s30 is overwritten.
3. To ensure that the configuration has been transferred correctly, check that the Configuration CRC in the PNOZ s30 matches the CRC that is shown in the title bar in the PNOZsigma Configurator.



Note: Download mode can be cancelled using the rotary knob.

	1.		2.
<b>DOWNLOAD MODE</b>		<b>Cancel DOWNLOAD MODE?</b>	

## 9.2 Transfer project from PNOZ s30 to the PNOZsigma Configurator



It is possible to download a configuration from PNOZ s30 to the PNOZsigma Configurator and to create a new project there.

**Transfer project via chip card from PNOZ s30 to the PNOZsigma Configurator**

1. Ensure that the required configuration is saved to the chip card (see chapter [Write data to chip card](#)  60]).
2. Remove the chip card from the PNOZ s30 and insert it into the holder for the chip card reader.
3. In the PNOZsigma Configurator, click on the start page on the  button to download the configuration to the chip card.

When the download is complete, the configuration is created in PNOZsigma Configurator as a project.

**Transfer project via cable from PNOZ s30 to the PNOZsigma Configurator**

1. Connect the PNOZ s30 with a free USB interface of your computer. To do this, use the cable **PNOZ s30 USB-configuration-cable** which is available at Pilz as an [accessory](#)  127].
2. In the PNOZsigma Configurator, click on the start page on the button  to download the configuration to the PNOZ s30.

**Please not when downloading from a PNOZ s30 Version 2.2:**

When transferring the configuration from a PNOZ s30 with device version 2.2, the CRC of the PNOZ s30 configuration must be entered into the PNOZsigma Configurator, before you create the project in PNOZsigma Configurator.

When the download is complete, the configuration is created in PNOZsigma Configurator as a project.

### **Replace project in PNOZsigma Configurator**

If a project with the same name already exists in the PNOZsigma Configurator, you can write over the existing project or open the new project and save it under a different name. By changing the project name, the configuration CRC is also changed.



#### **NOTICE**

##### **Please note:**

Identical project configurations have the same check sum when the project name has not been changed.



## 10 Function test during commissioning



### **CAUTION!**



It is essential to check that the safety devices operate correctly



























- After changing the configuration
- After downloading a project from the PNOZsigma Configurator to the PNOZ s30

# 11 Operation and diagnostics

## 11.1 LED indicators

### Legend

-  LED on
-  LED flashes

LED						Error
Power	In1	In2	Rel 1	Rel 2	Fault	
						Supply voltage is present
						At least one of the internal supply voltages is outside the permitted range.
						A high signal is present on track A (terminal In1 or RJ45).
						Error on track In1 or A
						A high signal is present on track B (terminal In2 or RJ45).
						Error on track In2 or B
						Relay output 1 is switched on
						Error on relay output 1
						Relay output 2 is switched on
						Error on relay output 2
						Fault that can be repaired by the user leading to safe condition.
						Internal error leading to a safe condition.

## 11.2 Display

### 11.2.1 Error stack entries

Up to 20 status and error messages are stored in the unit and can be called up via the display (see section entitled "Display Menu – Configuration – Menu Overview"). They can also be called up if the error has been recovered and the unit has been restarted.

The following information is shown on the display:

- ▶ Sequential number of an error stack entry (1 ... 20).
- ▶ Error number (0 ... 65 535)

- ▶ Error category
  - User-recoverable errors  
are described in the following list  
Remedy: recover error; if necessary contact Pilz
  - Internal errors (system errors, all errors that are not described in the list)  
Remedy: switch device on and off, contact Pilz
- ▶ System time
- ▶ Additional information for support
  - Error source (GG A/ GG B/ EM A/ EM B)
  - Error parameters 1 ... 4

Please note:

In many cases, one error can lead to subsequent errors. For this reason, start troubleshooting with the first error that occurred.

If recoverable errors and internal errors have been entered at the same system time, internal errors can be ignored because in this case, the causes of the error are always recoverable errors.

## 11.2.2 Current error messages

If an error is detected, the "Fault" LED lights up on the device and an error message appears on the display (see error stack).

Up to 8 current error messages are shown on the display.

A message is shown until the error is recovered and the device has been switched off and then on again, the software is restarted or an error acknowledgement has been carried out.

Errors can be acknowledged via the select inputs, by configuring the special function "Error acknowledgement". User-recoverable errors can be acknowledged via this function; the following errors are an exception:

Error numbers 2, 4, 5 as these are purely informative.

Error number 2000, as this is acknowledged automatically during recovery.

Error numbers 3, 5003, 10268 and 10269.

All errors with a number  $\geq 30000$

**List of errors**

Error no.	Error message	Description	Remedy
2	PNOZ s30 cold started	The unit is ready for operation (Error stack entry)	For information only
3	Brown Out occurred	Supply voltage too low	Check supply voltage
4	Softwarerestart	The PNOZ s30 has been restarted via a software restart. This can be caused by one of the following reasons: <ul style="list-style-type: none"> <li>▶ Restart via the Restart menu</li> <li>▶ Restart via the PNOZsigma Configurator</li> <li>▶ Restart using the special function "Error acknowledgement"</li> <li>▶ Restart using the special function "Restart"</li> </ul>	For information only
5	SIM loaded	Device parameters have been transferred from the chip card	For information only
2000	Wrong signal A ... /Z	Implausible signal from the encoder	Ensure that there is no open circuit in the wiring of input A ... /Z <ul style="list-style-type: none"> <li>▶ Ensure that the correct encoder is configured and connected</li> <li>▶ Ensure that the encoder operates correctly</li> </ul>
2001	AB frequency > fmax AB	The maximum frequency of the encoder at tracks AB was exceeded	<ul style="list-style-type: none"> <li>▶ Enter a max. frequency for "Track AB fmax" that is not exceeded during normal operation</li> <li>▶ Ensure that a suitable encoder is connected</li> </ul>
2004	Z frequency > fmax Z	The maximum frequency of the encoder at track Z was exceeded	<ul style="list-style-type: none"> <li>▶ Enter a max. frequency for "Track AB fmax" that is not exceeded during normal operation</li> <li>▶ Ensure that a suitable encoder is connected</li> </ul>

Error no.	Error message	Description	Remedy
2007	fAB / fZ does not fit!	The ratio of the AB frequency does not match the fAB/fZ ratio	<ul style="list-style-type: none"> <li>▶ Change fAB/fZ in the menu</li> <li>▶ Ensure that there is no broken shear pin or slippage</li> <li>▶ Ensure that both encoders operate correctly</li> </ul>
4010	FL K1K2 of Extens.Device	Feedback loop K1-K2 of expansion module open	<ul style="list-style-type: none"> <li>▶ Ensure that the feedback loop is wired correctly</li> <li>▶ Ensure that the expansion module operates correctly</li> </ul>
4011	FL K3K4 of Extens.Device	Feedback loop K3-K4 of expansion module open	<ul style="list-style-type: none"> <li>▶ Ensure that the feedback loop is wired correctly</li> <li>▶ Ensure that the expansion module operates correctly</li> </ul>
4012	Expansion connector is missing	The terminator on the expansion interface is not connected	<ul style="list-style-type: none"> <li>▶ Ensure that the appropriate yellow terminator is connected.</li> <li>▶ Ensure that the expansion module operates correctly</li> </ul>
5000	Input Device undefined!	No encoder configured (delivery condition, default values)	<ul style="list-style-type: none"> <li>▶ Create the encoder configuration in the "Encoder settings" menu</li> </ul>
5003	Pos. or Dir. not with Ini	Position monitoring or direction monitoring configured, although "Initiator" is selected as the encoder	<ul style="list-style-type: none"> <li>▶ Do not configure direction or position monitoring</li> <li>▶ Select rotary encoder</li> </ul>
6000	"AB frequency deviation"	Frequency difference between proximity switches A and B e.g. due to edge jitter at standstill over an extended period	<ul style="list-style-type: none"> <li>▶ Reset error via a valid signal over the standstill limit, a falling edge at input S34 (Start) or via the special function "Error acknowledgement".</li> <li>▶ Ensure that the proximity switches operate correctly</li> </ul>
7000	Select Input not 1 v .4 !	A parameter set other than P1, P2, P4 or P8 is selected in mode "1 from 4".	<ul style="list-style-type: none"> <li>▶ Select a longer delay time for the select inputs in order to filter out invalid signals resulting from contact bounce or an intermediate state</li> </ul>
10241	Stuck at High Track A or /A	A high signal is always present at track A or /A.	<ul style="list-style-type: none"> <li>▶ Ensure that the encoders are configured correctly</li> <li>▶ Ensure that the encoder operates correctly</li> <li>▶ Ensure that there is no short circuit in the wiring</li> </ul>

Error no.	Error message	Description	Remedy
10242	Stuck at Low Track A or /A	A low signal is always present at track A or /A.	<ul style="list-style-type: none"> <li>▶ Ensure that the encoders are configured correctly</li> <li>▶ Ensure that the encoder operates correctly</li> <li>▶ Ensure that there is no short circuit in the wiring</li> </ul>
10243	Stuck at High Track B or /B	A high signal is always present at track B or /B.	<ul style="list-style-type: none"> <li>▶ Ensure that the encoders are configured correctly</li> <li>▶ Ensure that the encoder operates correctly</li> <li>▶ Ensure that there is no short circuit in the wiring</li> </ul>
10244	Stuck at Low Track B or /B	A low signal is always present at track B or /B.	<ul style="list-style-type: none"> <li>▶ Ensure that the encoders are configured correctly</li> <li>▶ Ensure that the encoder operates correctly</li> <li>▶ Ensure that there is no short circuit in the wiring</li> </ul>
10245	Signal Offset Track A	The signal at track A has a DC offset	<ul style="list-style-type: none"> <li>▶ Ensure that the encoders are configured correctly</li> <li>▶ Ensure that the encoder operates correctly</li> <li>▶ Ensure that the wiring is correct</li> </ul>
10246	Signal Offset Track /A	The signal at track /A has a DC offset	<ul style="list-style-type: none"> <li>▶ Ensure that the encoders are configured correctly</li> <li>▶ Ensure that the encoder operates correctly</li> <li>▶ Ensure that the wiring is correct</li> </ul>
10247	Signal Offset Track B	The signal at track B has a DC offset	<ul style="list-style-type: none"> <li>▶ Ensure that the encoders are configured correctly</li> <li>▶ Ensure that the encoder operates correctly</li> <li>▶ Ensure that the wiring is correct</li> </ul>
10248	Signal Offset Track /B	The signal at track /B has a DC offset	<ul style="list-style-type: none"> <li>▶ Ensure that the encoders are configured correctly</li> <li>▶ Ensure that the encoder operates correctly</li> <li>▶ Ensure that the wiring is correct</li> </ul>

Error no.	Error message	Description	Remedy
10249	Signal error AB: Sin2 Cos2	No feasible signal at the tracks AB	<ul style="list-style-type: none"> <li>▶ Ensure that the encoders are configured correctly</li> <li>▶ Ensure that the encoder operates correctly</li> <li>▶ Ensure that the wiring is correct</li> <li>▶ Check supply voltage</li> </ul>
10250	Difference- Signal Error	No feasible signal at the tracks A and /A or B and /B	<ul style="list-style-type: none"> <li>▶ Ensure that the encoders are configured correctly</li> <li>▶ Ensure that the encoder operates correctly</li> <li>▶ Ensure that the wiring is correct</li> <li>▶ Ensure that there is not too much interference on the encoder signals</li> </ul>
10251	Z-Index missing	No index signal at track Z	<ul style="list-style-type: none"> <li>▶ Ensure that the encoders are configured correctly</li> <li>▶ Ensure that the encoder operates correctly</li> <li>▶ Ensure that the wiring is correct</li> <li>▶ Check the configuration of the frequency ratio f<sub>AB</sub> to f<sub>Z</sub></li> </ul>
10252	Z-Index at wrong position	No feasible signal at track Z	<ul style="list-style-type: none"> <li>▶ Ensure that the encoders are configured correctly</li> <li>▶ Ensure that the encoder operates correctly</li> <li>▶ Ensure that the wiring is correct</li> <li>▶ Check the configuration of the frequency ratio f<sub>AB</sub> to f<sub>Z</sub></li> </ul>
10255	Signal on inverted Track	The inverted tracks carry a voltage signal Target state: no signal (not connected)	<ul style="list-style-type: none"> <li>▶ Ensure that the encoders are configured correctly</li> <li>▶ Ensure that the wiring is correct</li> </ul>
10256	Ini pnp pnp both inactive	Both proximity switches are inactive at the same time	<ul style="list-style-type: none"> <li>▶ Install proximity switches so that one proximity switch is always activated.</li> <li>▶ Ensure that the encoders are configured correctly</li> <li>▶ Ensure that the proximity switches operate correctly</li> <li>▶ Ensure that the supply voltage is present at the proximity switches</li> <li>▶ Ensure that the proximity switches are wired correctly</li> </ul>

Error no.	Error message	Description	Remedy
10257	Ini npn npn both inactive	Both proximity switches are inactive at the same time	<ul style="list-style-type: none"> <li>▶ Install proximity switches so that one proximity switch is always activated.</li> <li>▶ Ensure that the encoders are configured correctly</li> <li>▶ Ensure that the proximity switches operate correctly</li> <li>▶ Ensure that the supply voltage is present at the proximity switches</li> <li>▶ Ensure that the proximity switches are wired correctly</li> </ul>
10258	Ini pnp npn both inactive	Both proximity switches are inactive at the same time	<ul style="list-style-type: none"> <li>▶ Install proximity switches so that one proximity switch is always activated.</li> <li>▶ Ensure that the encoders are configured correctly</li> <li>▶ Ensure that the proximity switches operate correctly</li> <li>▶ Ensure that the supply voltage is present at the proximity switches</li> <li>▶ Ensure that the proximity switches are wired correctly</li> </ul>
10259	Ini npn pnp both inactive	Both proximity switches are inactive at the same time	<ul style="list-style-type: none"> <li>▶ Install proximity switches so that one proximity switch is always activated.</li> <li>▶ Ensure that the encoders are configured correctly</li> <li>▶ Ensure that the proximity switches operate correctly</li> <li>▶ Ensure that the supply voltage is present at the proximity switches</li> <li>▶ Ensure that the proximity switches are wired correctly</li> </ul>
10260	Ini Signal /A Not permitted	Invalid signal at track /A	<ul style="list-style-type: none"> <li>▶ Ensure that the encoders are configured correctly</li> <li>▶ Ensure that the wiring is correct</li> </ul>
10261	Ini Signal /B Not permitted	Invalid signal at track /B	<ul style="list-style-type: none"> <li>▶ Ensure that the encoders are configured correctly</li> <li>▶ Ensure that the wiring is correct</li> </ul>
10262	Ini Signal A invalid	The signal at track A is outside the permitted voltage range	<ul style="list-style-type: none"> <li>▶ Ensure that the encoders are configured correctly</li> <li>▶ Ensure that the wiring is correct</li> </ul>



Error no.	Error message	Description	Remedy
10263	Ini Signal B invalid	The signal at track B is outside the permitted voltage range	<ul style="list-style-type: none"> <li>▶ Ensure that the encoders are configured correctly</li> <li>▶ Ensure that the wiring is correct</li> </ul>
10264	Track S Error wrong voltage	The voltage at track S is outside of the permissible range (e.g. because the encoder has detected an internal error and signals this via track S)	<ul style="list-style-type: none"> <li>▶ Check the encoders' supply voltage</li> <li>▶ Ensure that the wiring is correct</li> <li>▶ Check configuration of the min. and max. voltage at track S "Track S Umax / Umin"</li> <li>▶ Ensure that the encoder operates correctly</li> </ul>
10266	Stuck at High Track Z or /Z	A high signal is always present at track Z or /Z.	<ul style="list-style-type: none"> <li>▶ Ensure that the encoders are configured correctly</li> <li>▶ Ensure that the encoder operates correctly</li> <li>▶ Ensure that there is no short circuit in the wiring</li> </ul>
10267	Stuck at Low Track Z or /Z	A low signal is always present at track Z or /Z.	<ul style="list-style-type: none"> <li>▶ Ensure that the encoders are configured correctly</li> <li>▶ Ensure that the encoder operates correctly</li> <li>▶ Ensure that there is no short circuit in the wiring</li> </ul>
10268	Signal error Track A or B	No feasible signal at the tracks AB	<ul style="list-style-type: none"> <li>▶ Ensure that the encoders are configured correctly</li> <li>▶ Ensure that the encoder operates correctly</li> <li>▶ Ensure that the wiring is correct</li> <li>▶ Check supply voltage.</li> </ul>
10269	Signal error Track /A or /B	No feasible signal at the tracks /A/B	<ul style="list-style-type: none"> <li>▶ Ensure that the encoders are configured correctly</li> <li>▶ Ensure that the encoder operates correctly</li> <li>▶ Ensure that the wiring is correct</li> <li>▶ Check supply voltage.</li> </ul>
31014	System error	An error was detected while monitoring the internally generated 24 V voltage.	<ul style="list-style-type: none"> <li>▶ Check whether device immediately recognises the error again after a restart</li> <li>▶ Device defective, exchange</li> </ul>
31015	System error	An error was detected while monitoring the internally generated 5 V voltage.	<ul style="list-style-type: none"> <li>▶ Check whether device immediately recognises the error again after a restart</li> <li>▶ Device defective, exchange</li> </ul>

Error no.	Error message	Description	Remedy
31016	System error	An error was detected while monitoring the internally generated 3.3 V voltage.	<ul style="list-style-type: none"> <li>▶ Check whether device immediately recognises the error again after a restart</li> <li>▶ Device defective, exchange</li> </ul>
31017	System error	An error was detected while monitoring the internally generated VCC voltage.	<ul style="list-style-type: none"> <li>▶ Check whether device immediately recognises the error again after a restart</li> <li>▶ Device defective, exchange</li> </ul>
32003	System error	A difference was detected when comparing the process image of the outputs with the adjacent channel	<ul style="list-style-type: none"> <li>▶ Under Settings/Permanent display, select no time display</li> <li>▶ Note all the additional parameters and contact Support</li> </ul>
32004	System error	The fed-back state of the "Relay Control" root relay does not correspond to the target state	<ul style="list-style-type: none"> <li>▶ Device defective, exchange</li> </ul>
32005	System error	The fed-back state of the relay Rel1 does not correspond to the target state	<ul style="list-style-type: none"> <li>▶ Device defective, exchange</li> <li>▶ Use another, functioning relay output</li> </ul>
32006	System error	The fed-back state of the relay Rel2 does not correspond to the target state	<ul style="list-style-type: none"> <li>▶ Device defective, exchange</li> <li>▶ Use another, functioning relay output</li> </ul>
35043	System error	<p>An output for synchronous start was selected at the same time as an output assignment that is not compatible with a synchronous start.</p> <p>This can happen when the configuration of a PNOZ s30 device version &lt;v3.0 has been loaded</p>	<ul style="list-style-type: none"> <li>▶ Deactivate synchronous start setting -&gt; see <a href="#">Synchronous start [24]</a></li> <li>▶ Or, if a synchronous start is necessary</li> <li>▶ Deactivate analogue output, as it is not compatible with a synchronous start -&gt; see <a href="#">Analogue output [26]</a></li> <li>▶ Deactivate error output switch function on outputs assigned to a synchronous start -&gt; see <a href="#">Switch functions [32]</a></li> </ul>
41215	System error	The device was switched to the stop state. This is a subsequent error that occurs only in combination with other errors.	For information only
65535	System error	No error present. The empty error memory was wrongly interpreted as an error.	For information only

### 11.2.3 Open circuit message

If an open circuit error is detected, the "Fault" LED lights up on the device, the outputs are switched off and an error message appears on the display.

The error message is continually updated. It will be displayed until the error is rectified.

The outputs will not switch back on until all the start-up conditions are met.

Error message	Description	Remedy
Error Signal: A/A B/B Z/Z	No feasible signal at one or more tracks	- Ensure that there is no open circuit in the wiring of tracks A... /Z  - Ensure that the correct encoder is configured and connected  - Ensure that the encoder operates correctly.

### 11.2.4 Frequency difference message on proximity switch

If a frequency difference error is detected, the "Fault" LED lights up on the device and a warning message appears on the display: "AB frequency deviation".

The warning message disappears automatically once valid signals are again present for both proximity switches. The Fault LED also goes out.

If the warning message appears, it will no longer be possible to carry out configured frequency range monitoring. The output or outputs will react as if the configured range has been violated.

If the frequency difference is present for an extended period, without a valid signal, greater than the global standstill frequency, from the two proximity switches, error message 6000 will appear (see "Current error messages"), all outputs will switch off and the Fault LED will light up.

The error message disappears automatically if

- ▶ Valid signals, greater than the global standstill frequency, are detected from both proximity switches
- or
- ▶ A falling edge is detected at start input S34

The outputs will not switch back on until all the start-up conditions are met.

Warning message	Description	Remedy
AB frequency deviation	Frequency of the proximity switch at track A differs from the frequency of the proximity switch at track B for too long and by too much.	- Ensure that the proximity switches operate correctly  - Check whether a proximity switch constantly switches due to the drive's edge jitter.

## 11.3 Function test of the relay outputs

When the relay outputs are switched on, the mechanical contact on the relay cannot be tested automatically. Depending on the operational environment, measures to detect the non-opening of switching elements may be required under some circumstances.

When the product is used in accordance with the European Machinery Directive, a check must be carried out to ensure that the safety contacts on the relay outputs open correctly. Open the safety contacts (switch off output) and start the device again, so that the internal diagnostics can check that the safety contacts open correctly

- ▶ for SIL 3/PL e at least 1x per month
- ▶ for SIL 2/PL d at least 1x per year

## 12 Technical details

<b>General</b>		
Certifications	CCC, CE, EAC, TÜV, UKCA, cULus Listed	CCC, CE, EAC, TÜV, UKCA, cULus Listed
<b>Electrical data</b>		
Supply voltage		
Voltage	24 - 240 V	24 - 240 V
Kind	DC	DC
Voltage tolerance	-15 %/+10 %	-15 %/+10 %
Output of external power supply (DC)	5,5 W	5,5 W
Residual ripple DC	160 %	160 %
Supply voltage		
Voltage	48 - 240 V	48 - 240 V
Kind	AC	AC
Voltage tolerance	-15 %/+10 %	-15 %/+10 %
Output of external power supply (AC)	9 VA	9 VA
Frequency range AC	50 - 60 Hz	50 - 60 Hz
Duty cycle	100 %	100 %
External unit fuse protection F1 min.	1 A	1 A
External unit fuse protection F1 max.	Max. conductor cross section	Max. conductor cross section
<b>Proximity switch input</b>		
Number of inputs	2	2
Input signal level		
Signal level at "1"	11 - 30 V	11 - 30 V
Signal level at g0 h	-0,5 - 3 V	-0,5 - 3 V
Input resistance	22 kOhm	22 kOhm
Input's frequency range	0 - 1.000 kHz	0 - 1.000 kHz
Configurable monitoring frequency		
without hysteresis	10 mHz - 1.000 kHz	10 mHz - 1.000 kHz
<b>Incremental encoder input</b>		
Number of inputs	1	1
Connection type	RJ45 female connector, 8-pin	RJ45 female connector, 8-pin
Input signal level	0,5 - 30 Vss	0,5 - 30 Vss
Phase position for the differential signals A, /A and B,/B	90° ±30°	90° ±30°
Overload protection	-50 - 65 V	-50 - 65 V
Input resistance	20 kOhm	20 kOhm
Input's frequency range	0 - 1.000 kHz	0 - 1.000 kHz
Configurable monitoring frequency		
Without hysteresis	10 mHz - 1.000 kHz	10 mHz - 1.000 kHz

<b>Inputs</b>		
Voltage at		
Start circuit DC	24 V	24 V
Feedback loop DC	24 V	24 V
Current at		
Start circuit DC	5 mA	5 mA
Feedback loop DC	5 mA	5 mA
Max. inrush current impulse		
Current pulse, feedback loop	0,06 A	0,06 A
Pulse duration, feedback loop	0,8 ms	0,8 ms
Current pulse, start circuit	0,06 A	0,06 A
Pulse duration, start circuit	0,8 ms	0,8 ms
<b>Reset input</b>		
Quantity	4	4
Low signal	-3 - 5 V	-3 - 5 V
High signal	15 - 30 V	15 - 30 V
Current	5 mA	5 mA
<b>Analogue outputs</b>		
Number of analogue outputs	1	1
Type of analogue outputs	Current	Current
Output range	0 .. 20 mA, 4 .. 20 mA	0 .. 20 mA, 4 .. 20 mA
Max. open circuit voltage	22 V	22 V
Max. permitted resistive load	500 Ohm	500 Ohm
Typ. processing time of the analogue output	8 ms	8 ms
Accuracy of analogue output	1,5 % (bei 25 °C)	1,5 % (bei 25 °C)
<b>Semiconductor outputs</b>		
Quantity	4	4
Voltage	24 V	24 V
Current	50 mA	50 mA
External supply voltage	24 V	24 V
Voltage tolerance	-20 %/+20 %	-20 %/+20 %
Residual current at "0" signal	0,5 mA	0,5 mA
Max. internal voltage drop	0,2 V	0,2 V
Conditional rated short circuit current	100 A	100 A
Utilisation category in accordance with EN 60947-1	DC-12	DC-12
<b>Relay outputs</b>		
Number of output contacts		
Safety contacts (N/O), instantaneous	2	2
Auxiliary contacts (N/C)	2	2
Max. short circuit current I <sub>K</sub>	1 kA	1 kA
Utilisation category in accordance with the standard	EN 60947-4-1	EN 60947-4-1

## Relay outputs

Utilisation category of safety con-  
tacts

AC1 at	<b>240 V</b>	<b>240 V</b>
Min. current	<b>0,01 A</b>	<b>0,01 A</b>
Max. current	<b>4 A</b>	<b>4 A</b>
Max. power	<b>1000 VA</b>	<b>1000 VA</b>
DC1 at	<b>24 V</b>	<b>24 V</b>
Min. current	<b>0,01 A</b>	<b>0,01 A</b>
Max. current	<b>4 A</b>	<b>4 A</b>
Max. power	<b>100 W</b>	<b>100 W</b>

Utilisation category of auxiliary con-  
tacts

AC1 at	<b>240 V</b>	<b>240 V</b>
Min. current	<b>0,01 A</b>	<b>0,01 A</b>
Max. current	<b>4 A</b>	<b>4 A</b>
Max. power	<b>1000 VA</b>	<b>1000 VA</b>
DC1 at	<b>24 V</b>	<b>24 V</b>
Min. current	<b>0,01 A</b>	<b>0,01 A</b>
Max. current	<b>4 A</b>	<b>4 A</b>
Max. power	<b>100 W</b>	<b>100 W</b>

Utilisation category

in accordance with the standard **EN 60947-5-1** **EN 60947-5-1**

Utilisation category of safety con-  
tacts

AC15 at	<b>230 V</b>	<b>230 V</b>
Max. current	<b>3 A</b>	<b>3 A</b>
DC13 (6 cycles/min) at	<b>24 V</b>	<b>24 V</b>
Max. current	<b>4 A</b>	<b>4 A</b>

Utilisation category of auxiliary con-  
tacts

AC15 at	<b>230 V</b>	<b>230 V</b>
Max. current	<b>3 A</b>	<b>3 A</b>
DC13 (6 cycles/min) at	<b>24 V</b>	<b>24 V</b>
Max. current	<b>4 A</b>	<b>4 A</b>

Utilisation category in accordance  
with UL

Voltage with current	<b>240 V AC G.U. (same polarity)</b> <b>4 A</b>	<b>240 V AC G.U. (same polarity)</b> <b>4 A</b>
Voltage with current	<b>24 V DC G. U.</b> <b>4 A</b>	<b>24 V DC G. U.</b> <b>4 A</b>

### Relay outputs

External contact fuse protection,  
safety contacts

in accordance with the standard	<b>EN 60947-5-1</b>	<b>EN 60947-5-1</b>
Max. melting integral	<b>66 A<sup>2</sup>s</b>	<b>66 A<sup>2</sup>s</b>
Blow-out fuse, quick	<b>6 A</b>	<b>6 A</b>
Blow-out fuse, slow	<b>4 A</b>	<b>4 A</b>
Blow-out fuse, gG	<b>6 A</b>	<b>6 A</b>
Circuit breaker 24V AC/DC, characteristic B/C	<b>4 A</b>	<b>4 A</b>

External contact fuse protection,  
auxiliary contacts

Max. melting integral	<b>66 A<sup>2</sup>s</b>	<b>66 A<sup>2</sup>s</b>
Blow-out fuse, quick	<b>6 A</b>	<b>6 A</b>
Blow-out fuse, slow	<b>4 A</b>	<b>4 A</b>
Blow-out fuse, gG	<b>6 A</b>	<b>6 A</b>
Circuit breaker, 24 V AC/DC, characteristic B/C	<b>4 A</b>	<b>4 A</b>

Conventional thermal current

<b>4 A</b>	<b>4 A</b>
------------	------------

Contact material

<b>AgCuNi + 0,2 µm Au</b>	<b>AgCuNi + 0,2 µm Au</b>
---------------------------	---------------------------

### Times

Switch-on delay

with automatic start typ.	<b>15 ms</b>	<b>15 ms</b>
with automatic start max.	<b>50 ms</b>	<b>50 ms</b>
with automatic start after power on typ.	<b>3.920 ms</b>	<b>3.920 ms</b>
with automatic start after power on max.	<b>4 s</b>	<b>4 s</b>
with manual start typ.	<b>40 ms</b>	<b>40 ms</b>
with manual start max.	<b>100 ms</b>	<b>100 ms</b>

Delay-on de-energisation

with power failure typ. UB 240 V	<b>210 ms</b>	<b>210 ms</b>
with power failure max. UB 240 V	<b>230 ms</b>	<b>230 ms</b>
with power failure typ. UB 24 V	<b>45 ms</b>	<b>45 ms</b>
with power failure max. UB 24 V	<b>50 ms</b>	<b>50 ms</b>
after safety function is triggered typ.	<b>8 ms</b>	<b>8 ms</b>
after safety function is triggered max.	<b>15 ms</b>	<b>15 ms</b>

Recovery time at max. switching  
frequency 1/s

after power failure	<b>4 s</b>	<b>4 s</b>
after safety function is triggered	<b>1 s</b>	<b>1 s</b>

Reaction time after limit value is  
exceeded

<b>1/f_ist + 16 ms</b>	<b>1/f_ist + 16 ms</b>
------------------------	------------------------



<b>Times</b>		
Waiting period with a monitored start		
with rising edge	<b>30 ms</b>	<b>30 ms</b>
with falling edge	<b>30 ms</b>	<b>30 ms</b>
Min. start pulse duration with a monitored start		
with falling edge	<b>30 ms</b>	<b>30 ms</b>
with rising edge	<b>30 ms</b>	<b>30 ms</b>
Supply interruption before de-energisation		
	<b>20 ms</b>	<b>20 ms</b>
Switch delay (selectable)		
	<b>0 - 30 s</b>	<b>0 - 30 s</b>
Delay on the select inputs (selectable)		
	<b>0 - 30 s</b>	<b>0 - 30 s</b>
Start-up delay (selectable)		
	<b>0 - 600 s</b>	<b>0 - 600 s</b>
<b>Environmental data</b>		
Climatic suitability		
	<b>EN 60068-2-78</b>	<b>EN 60068-2-78</b>
Ambient temperature		
Temperature range	<b>-20 - 55 °C</b>	<b>-20 - 55 °C</b>
Storage temperature		
Temperature range	<b>-40 - 85 °C</b>	<b>-40 - 85 °C</b>
Climatic suitability		
Humidity	<b>93 % r. h. at 40 °C</b>	<b>93 % r. h. at 40 °C</b>
Condensation during operation		
	<b>Not permitted</b>	<b>Not permitted</b>
EMC		
	<b>EN 60947-5-1, EN 61000-6-2, EN 61000-6-3, EN 61326-3-1</b>	<b>EN 60947-5-1, EN 61000-6-2, EN 61000-6-3, EN 61326-3-1</b>
Vibration		
in accordance with the standard	<b>EN 60068-2-6</b>	<b>EN 60068-2-6</b>
Frequency	<b>10 - 55 Hz</b>	<b>10 - 55 Hz</b>
Amplitude	<b>0,35 mm</b>	<b>0,35 mm</b>
Airgap creepage		
in accordance with the standard	<b>EN 60947-1</b>	<b>EN 60947-1</b>
Overvoltage category	<b>II</b>	<b>II</b>
Pollution degree	<b>2</b>	<b>2</b>
Rated insulation voltage		
	<b>250 V</b>	<b>250 V</b>
Rated impulse withstand voltage		
	<b>4 kV</b>	<b>4 kV</b>
Protection type		
Housing	<b>IP30</b>	<b>IP30</b>
Terminals	<b>IP20</b>	<b>IP20</b>
Mounting area (e.g. control cabinet)	<b>IP54</b>	<b>IP54</b>
<b>Mechanical data</b>		
Mounting position		
	<b>horizontally on mounting rail</b>	<b>horizontally on mounting rail</b>
Mechanical life		
	<b>10,000,000 cycles</b>	<b>10,000,000 cycles</b>

<b>Mechanical data</b>		
Material		
Bottom	<b>PC</b>	<b>PC</b>
Front	<b>PC</b>	<b>PC</b>
Top	<b>PC</b>	<b>PC</b>
Connection type	<b>Screw terminal</b>	<b>Spring-loaded terminal</b>
Mounting type	<b>plug-in</b>	<b>plug-in</b>
Conductor cross section with screw terminals		
1 core flexible	<b>0,25 - 2,5 mm<sup>2</sup>, 24 - 12 AWG</b>	–
2 core with the same cross section, flexible with crimp connectors, no plastic sleeve	<b>0,25 - 1 mm<sup>2</sup>, 24 - 16 AWG</b>	–
2 core with the same cross section, flexible without crimp connectors or with TWIN crimp connectors	<b>0,2 - 1,5 mm<sup>2</sup>, 24 - 16 AWG</b>	–
Torque setting with screw terminals	<b>0,5 Nm</b>	–
Stripping length with screw terminals	<b>8 mm</b>	–
Conductor cross section with spring-loaded terminals: Flexible with/without crimp connector	–	<b>0,2 - 2,5 mm<sup>2</sup>, 24 - 12 AWG</b>
Spring-loaded terminals: Terminal points per connection	–	<b>2</b>
Stripping length with spring-loaded terminals	–	<b>9 mm</b>
Dimensions		
Height	<b>98 mm</b>	<b>100 mm</b>
Width	<b>45 mm</b>	<b>45 mm</b>
Depth	<b>120 mm</b>	<b>120 mm</b>
Weight	<b>405 g</b>	<b>400 g</b>

Where standards are undated, the 2021-12 latest editions shall apply.

## 12.1 Safety characteristic data



### NOTICE

You must comply with the safety characteristic data in order to achieve the required safety level for your plant/machine.

Operating mode	EN ISO 13849-1: 2015 PL	EN ISO 13849-1: 2015 Category	EN IEC 62061 SIL CL/ maximum SIL	EN IEC 62061 PFH <sub>D</sub> [1/h]	EN/IEC 61511 SIL	EN/IEC 61511 PFD	EN ISO 13849-1: 2015 T <sub>M</sub> [year]
Monitoring 1 encoder	PL d	Cat. 2	SIL 2	2,72E-08	SIL 2	2,39E-03	20
Monitoring 2 encoders	PL e	Cat. 4	SIL 3	1,73E-09	SIL 3	1,44E-04	20
Monitoring safe encoder	PL e	Cat. 4	SIL 3	3,07E-09	SIL 3	2,64E-04	20

Explanatory notes for the safety-related characteristic data:

- ▶ Safety characteristic data in accordance with EN IEC 62061 and EN/IEC 61511 was calculated based on EN/IEC 61508.
- ▶ T<sub>M</sub> is the maximum mission time in accordance with EN ISO 13849-1. The value also applies as the retest interval in accordance with EN/IEC 61508-6 and EN/IEC 61511 and as the proof test interval and mission time in accordance with EN IEC 62061.

All the units used within a safety function must be considered when calculating the safety characteristic data.



### INFORMATION

A safety function's SIL/PL values are **not** identical to the SIL/PL values of the units that are used and may be different. We recommend that you use the PAScal software tool to calculate the safety function's SIL/PL values.



### CAUTION!

It is essential to consider the relay's service life graphs. The relay outputs' safety-related characteristic data is only valid if the values in the service life graphs are met.

The PFH value depends on the switch frequency and the load of the relay output.

If the service life graphs are not accessible, the stated PFH value can be used irrespective of the switch frequency and the load, as the PFH value already considers the relay's B10d value as well as the failure rates of the other components.

## 12.2 Signal level of the encoders

Encoder type	"0" signal	"1" signal
HTL	-1.0 - 3.0 V	12.0 - 30.0 V
TTL	-0.5 - 0.8 V	3.5 - 5.5 V
PNP	-0.5 - 3.0 V	11.0 - 30.0 V
NPN	-0.5 - 3.0 V	11.0 - 30.0 V

Encoder type	DC offset	Amplitude differential	Reference voltage
Sin/Cos	2.5 V	1.0 V <sub>ss</sub>	-
Hiperface	2.5 V	1.0 V <sub>ss</sub>	2.5 V

## 13 Supplementary data

### 13.1 Service life graph of output relays

The service life graphs indicate the number of cycles from which failures due to wear must be expected. The wear is mainly caused by the electrical load; the mechanical load is negligible.

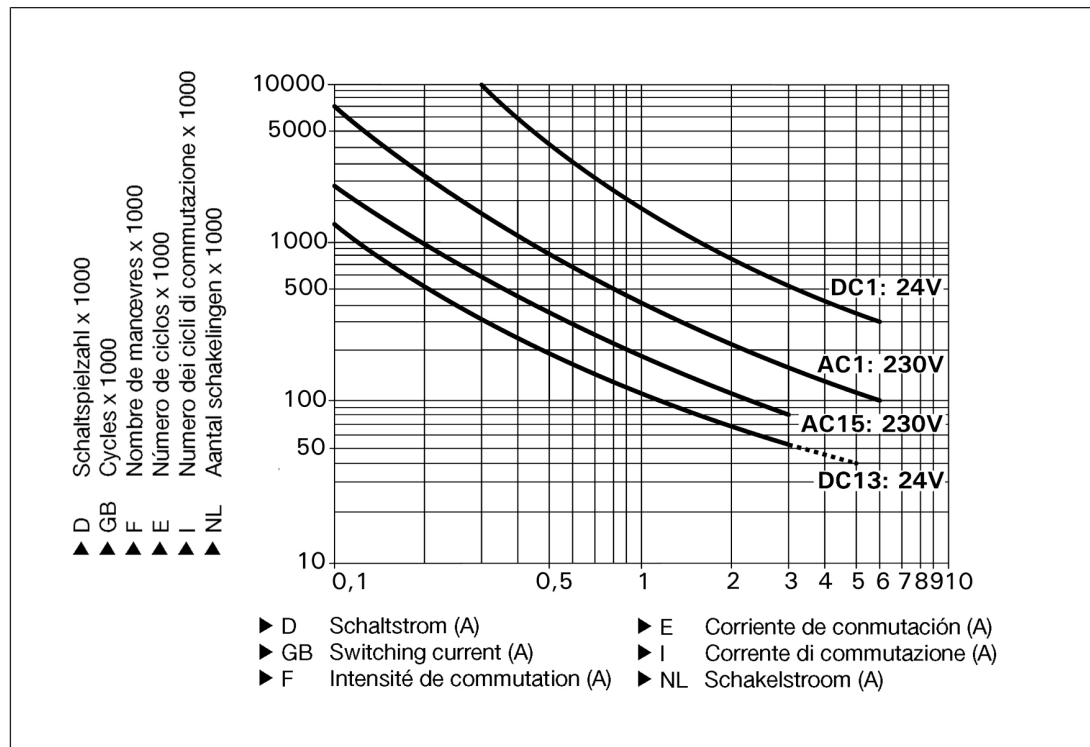

#### Example

- ▶ Inductive load: 0.2 A
- ▶ Utilisation category: AC15
- ▶ Contact service life: 1 000 000 cycles

Provided the application to be implemented requires fewer than 1 000 000 cycles, the PFH value (see [Technical details \[101\]](#)) can be used in the calculation.

To increase the service life, sufficient spark suppression must be provided on all relay contacts. With capacitive loads, any power surges that occur must be noted. With DC contactors, use flywheel diodes for spark suppression.

### 13.2 Permitted operating height

The values stated in the technical details apply to the use of the product in operating heights up to max. 2000 m above sea level. When used in greater heights, constraints have to be taken into account:

- ▶ Permitted maximum operating height 5000 m

- ▶ Reduction of rated insulation voltage and rated impulse withstand voltage for applications with safe separation:

Maximum operation height	Rated insulation voltage	Overvoltage category	Max. rated impulse withstand voltage
3000 m	150 V	II	2.5 kV
	100 V	III	2.5 kV
4000 m	150 V	II	2.5 kV
	100 V	III	2.5 kV
5000 m	100 V	II	1.5 kV
	24 V	III	0.8 kV

- ▶ Reduction of rated insulation voltage and rated impulse withstand voltage for applications with basic insulation:

Maximum operation height	Rated insulation voltage	Overvoltage category	Max. rated impulse withstand voltage
3000 m	250 V	II	2.5 kV
	150 V	III	2.5 kV
4000 m	250 V	II	2.5 kV
	150 V	III	2.5 kV
5000 m	150 V	II	1.5 kV
	100 V	III	1.5 kV

- ▶ From an operating height of 2000 m the max. permitted ambient temperature is reduced by 0.5 °C/100 m

Operating height	Permitted ambient temperature
3000 m	50 °C
4000 m	45 °C
5000 m	40 °C

## 13.3 Categories

### 13.3.1 Safety level

The maximum achievable safety level depends on the encoder, the wiring and the operating mode of the PNOZ s30.

In accordance with EN ISO 13849-1, values for the following characteristic data is needed to determine the performance level (PL):

- ▶ Category: Structure: single or dual-channel, single fault tolerance
- ▶ MTTFd: Mean time to dangerous failure
- ▶ DC: Diagnostic coverage
- ▶ CCF: Quantification of measures against common cause failure (necessary for Cat. 2 to 4)



**INFORMATION**

The safety-related characteristic data of the PNOZ s30 and all other devices that are used must be taken into account when calculating the safety level. We recommend that you use the PAscal software tool to calculate the safety function's SIL/PL values.

The safety assessments below only consider the *Sensor* and *PNOZ s30* subsystems. The *Actuator* subsystem depends on the application and must also be considered in the overall assessment.

Information on the safety-related characteristic data for the *Sensor* and *PNOZ s30* subsystems

Example:

Sensor subsystem			PNOZ s30 subsystem	
Category	MTTFd	DC	Operating mode	PFH [1/h]
2	Manufacturer-specific	90%	Monitoring 1 encoder	2,72E-08

The values for *Category* and *DC* can be set for the sensor subsystem, bearing in mind the restrictions stated in the respective chapter. The MTTFd value must be stated by the device manufacturer.

Assuming that all faults are dangerous, MTTF = MTTFd can be set.

The characteristic value MTTF is a property of the sensor, which may only be stated by the manufacturer.

**Forced dynamisation:**

When monitoring sensors with square output signals (TTL, HTL) or safe sensors, the axis must be moved within 8 hours so that the signal changes on all the connected tracks.

If forced dynamisation of the signals cannot be carried out every 8 hours, then the average frequency of a dangerous failure (PFH) is increased.

If the forced dynamisation time is increased, the stated PFH value must be multiplied by the following correction factors:

Forced dynamisation within 4 weeks → Correction factor 1.01

Forced dynamisation within 8 weeks → Correction factor 1.02

Key:

SRP/CS = Safety-related part of a control system (EN 13849-1, Tab. 2)

**13.3.2 Safety functions**

The following safe monitoring functions are available:

- ▶ Standstill
- ▶ Position
- ▶ Speed
- ▶ Speed range

- ▶ Direction
- ▶ Monitoring for broken shearpins

The safety functions of the PNOZ s30 are monitoring functions, whereby a safe output signal is used to show if defined limit values are exceeded.

The reaction function that takes place (e.g. shutting down the drive, activating a mechanical brake) when exceeded limit values are detected during the normal operation of the safety function must be defined and implemented by the machine/plant developer and does not form part of the PNOZ s30.

The monitoring function of the PNOZ s30 can be used to implement safety functions defined in the standard EN 61800-5-2 for Adjustable speed electrical power drive systems.

Safety functions in accordance with EN 61800-5-2	Implementation with PNOZ s30 safety function
Safe operating stop (SOS)	Standstill, position
Safely limited speed (SLS)	Speed
Safe speed range (SSR)	Speed range
Safe direction (SDI)	Direction
Safe speed monitoring (SSM)	Speed, speed range

### 13.3.3 Safety-related characteristic data for operation with non-safety-related rotary encoder without additional requirements

#### 13.3.3.1 Permitted encoder types and output signals

Permitted encoder types:

- ▶ Rotary non-safety-related encoders
- ▶ Linear non-safety-related encoders

Permitted output signals:

- ▶ Square output signals TTL, single ended
- ▶ Square output signals TTL, differential
- ▶ Square output signals HTL, single ended
- ▶ Square output signals HTL, differential
- ▶ Sin/Cos output signals 1Vss, reference voltage
- ▶ Sin/Cos output signals 1Vss, differential

#### 13.3.3.2 Safety-related architecture

To calculate the safety function you need the following data for the "Sensor" subsystem and "PNOZ s30" subsystem:

Sensor			PNOZ s30 subsystem	
Category	MTTFd	DC	Operating mode	PFH (1/h)
1*	Manufacturer-specific	0 %	Monitoring 1 encoder	2,72E-08



\*In accordance with EN ISO 13849-1, Category 1 is only met if the sensor is a "well-tried component".

**13.3.3.3 Achievable safety level**

Safety function	PL in accordance with EN ISO 13849-1: 2015	SIL CL in accordance with EN IEC 62061
Speed	PL c (Cat. 1)	-
Speed range		
Direction		
Standstill		
Position		

**13.3.4 Safety-related characteristic data for operation with non-safety-related rotary encoder with mechanical fault exclusion**

In accordance with EN 61800-5-2: 2007, Table D.16 (Motion and position feedback sensors), fault exclusions are permitted for faults in the mechanical connection between the sensor (encoder) and motor.

**13.3.4.1 Permitted encoder types and output signals**

Permitted encoder types:

- ▶ Rotary non-safety-related encoders

Permitted output signals:

- ▶ Sin/Cos output signals 1Vss, reference voltage
- ▶ Sin/Cos output signals 1Vss, differential



**NOTICE**

The signal tracks Cos and Sin must be generated independently. This means that the sine and cosine signals in the encoder must be conducted in independent channels, from the optics to the interface.

The two signal tracks must not be generated by a common processor

One signal may not be derived from the other signal via an electronic circuit.

### 13.3.4.2 Safety-related architecture

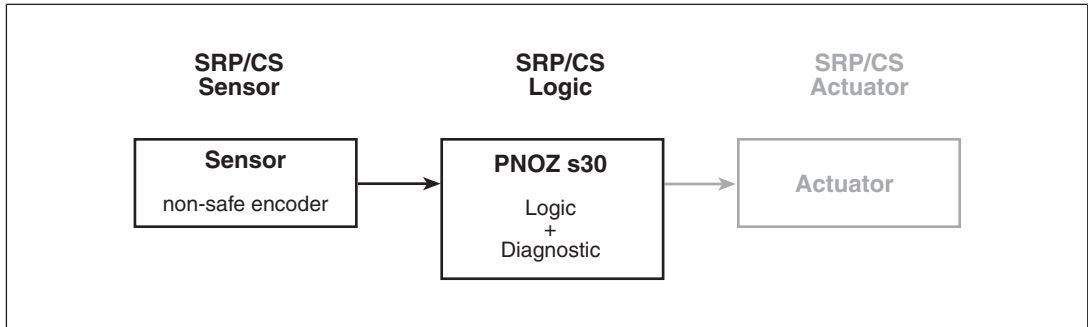

To calculate the safety function you need the following data for the "Sensor" subsystem and "PNOZ s30" subsystem:

Sensor			PNOZ s30 subsystem	
Category	MTTFd	DC	Operating mode	PFH (1/h)
2	Manufacturer-specific	90%	Monitoring 1 encoder	2,72E-08

### 13.3.4.3 Achievable safety level

Safety function	PL in accordance with EN ISO 13849-1: 2015	SIL CL in accordance with EN IEC 62061
Speed Speed range Direction Standstill Position	PL d (Cat. 2)	2

### 13.3.5 Safety-related characteristic data for operation with non-safety-related rotary encoder with diagnostics via the drive controller

The detection of encoder errors (diagnostics for the sensor subsystem via the evaluation device) can be supplemented with a drive controller.

#### 13.3.5.1 Permitted encoder types and output signals

Permitted encoder types:

- ▶ Rotary non-safety-related encoders
- ▶ Linear non-safety-related encoders

Permitted output signals:

- ▶ Square output signals TTL, single ended
- ▶ Square output signals TTL, differential
- ▶ Square output signals HTL, single ended
- ▶ Square output signals HTL, differential
- ▶ Sin/Cos output signals 1Vss, reference voltage
- ▶ Sin/Cos output signals 1Vss, differential

### 13.3.5.2 Requirements of the drive controller

- ▶ Parameters for the control loops and motor control must be set in such a way as to guarantee stable operation.  
Drag error detection (see below) must be capable of operating in accordance with the requirements of the safety function.
- ▶ The motor must be operated with a current impressing control procedure, based on the rotor position (field-oriented control). If the analogue track signals are idle, field-oriented control will brake and/or stop the rotor.
- ▶ The drive controller must be in position control operating mode.
- ▶ If a maximum error variable is exceeded (set/true comparison) the drive controller must switch to a fault condition and stop the drive (drag error detection). The error reaction to drag error detection should be a controlled motor stop.
- ▶ Fault detection via the error variable with subsequent shutdown must meet the requirements of the safety function, with regard to reaction times for example.
- ▶ The drive controller must evaluate the same incremental/sincos signals from the encoder for control as are processed by the safe evaluation device (important on encoders with combined analogue/digital interface).

### 13.3.5.3 Safety-related architecture

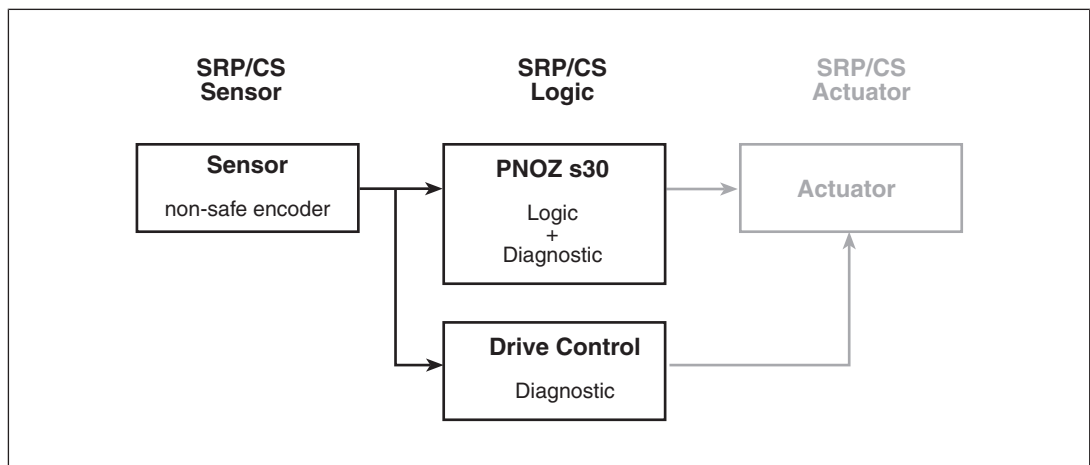

To calculate the safety function you need the following data for the "Sensor" subsystem and "PNOZ s30" subsystem:

Sensor			PNOZ s30 subsystem	
Category	MTTFd	DC	Operating mode	PFH (1/h)
2	Manufacturer-specific	90%	Monitoring 1 encoder	2,72E-08

**13.3.5.4 Achievable safety level**

Safety function	PL of EN ISO 13849-1: 2015	SIL CL in accordance with EN IEC 62061
Speed Speed range Direction Standstill Position	PL d (Cat.2)	2

**13.3.6 Safety-related characteristic data for operation with a safe rotary encoder**

Safe encoders are certified in accordance with EN 61508, EN 13849 and EN 62061. In order to achieve the safety level stated by the encoder, the safe evaluation device (PNOZ s30) must normally detect designated errors. Details of the safe encoder's requirements of the evaluation device can be found in the user documentation for the safe encoder. The encoder and evaluation device must be compatible.

**13.3.6.1 Permitted encoder types and output signals**

Permitted encoder types:

- ▶ Rotary safe encoder
- ▶ Linear safe encoder

Permitted output signals:

- ▶ Sin/Cos output signals 1Vss, reference voltage
- ▶ Sin/Cos output signals 1Vss, differential

**13.3.6.2 Safety-related architecture**

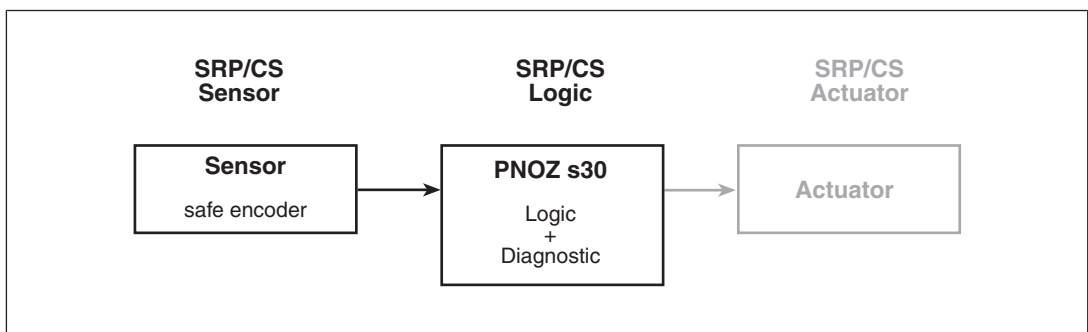

To calculate the safety function you need the following data for the "Sensor" subsystem and "PNOZ s30" subsystem:

Sensor			PNOZ s30 subsystem	
PL	SIL	PFH (1/h)	Operating mode	PFH (1/h)
See manufacturer			Monitoring safe encoder	3,07E-09

**13.3.6.3 Achievable safety level**

Safety function	PL in accordance with EN ISO 13849-1: 2015	SIL CL in accordance with EN IEC 62061
Speed Speed range Direction Standstill Position	PL e (Cat.4)	3

**13.3.7 Safety-related characteristic data for operation with a safe rotary encoder with Z index**

Safe encoders are certified in accordance with EN 61508, EN 13849 and EN 62061. In order to achieve the safety level stated by the encoder, the safe evaluation device (PNOZ s30) must normally detect designated errors. Details of the safe encoder's requirements of the evaluation device can be found in the user documentation for the safe encoder. The encoder and evaluation device must be compatible.

**13.3.7.1 Permitted encoder types and output signals**

Permitted encoder types:

- ▶ Rotary safe encoder
- ▶ Linear safe encoder

Permitted output signals:

- ▶ Square output signals TTL, differential with Z index
- ▶ Square output signals HTL, differential with Z index
- ▶ Sin/Cos output signals 1Vss, reference voltage with Z index
- ▶ Sin/Cos output signals 1Vss, differential with Z index

**13.3.7.2 Safety-related architecture**

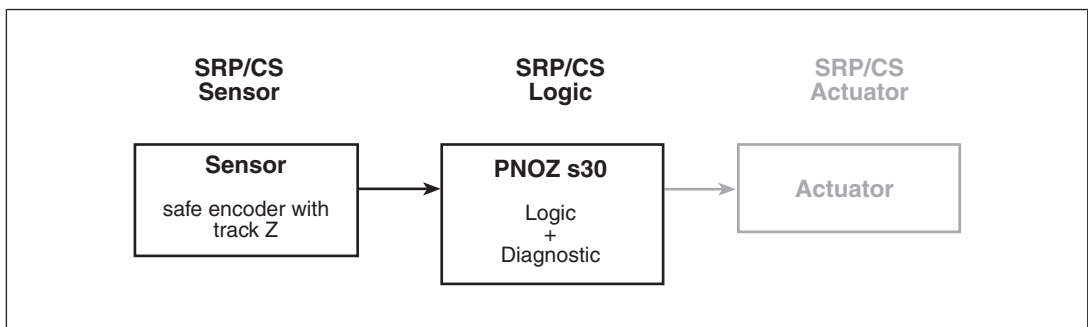

To calculate the safety function you need the following data for the "Sensor" subsystem and "PNOZ s30" subsystem:

Sensor			PNOZ s30 subsystem	
PL	SIL	PFH (1/h)	Operating mode	PFH (1/h)
See manufacturer			Monitoring 2 encoders	1,73E-09

### 13.3.7.3 Achievable safety level

Safety function	PL in accordance with EN ISO 13849-1: 2015	SIL CL in accordance with EN IEC 62061
Speed Speed range Direction Standstill Position	PL e (Cat.4)	3

### 13.3.8 Safety-related characteristic data for operation with non-safety-related rotary encoder and proximity switch

The speed monitoring of the non-safety-related encoder can be verified via an additional reference sensor.

#### 13.3.8.1 Permitted encoder types and output signals

##### Non-safety-related rotary encoder

Permitted encoder types:

- ▶ Rotary non-safety-related encoders
- ▶ Linear non-safety-related encoders

Permitted output signals:

- ▶ Square output signals TTL, single ended
- ▶ Square output signals TTL, differential
- ▶ Square output signals HTL, single ended
- ▶ Square output signals HTL, differential
- ▶ Sin/Cos output signals 1Vss, reference voltage
- ▶ Sin/Cos output signals 1Vss, differential

##### Reference sensor

Permitted encoder types:

- ▶ Rotary non-safety-related encoders
- ▶ Linear non-safety-related encoders
- ▶ Inductive proximity switches

Permitted output signals:

- ▶ Square output signals HTL, single ended
- ▶ Square output signal 24 V, pnp

### 13.3.8.2 Safety-related architecture

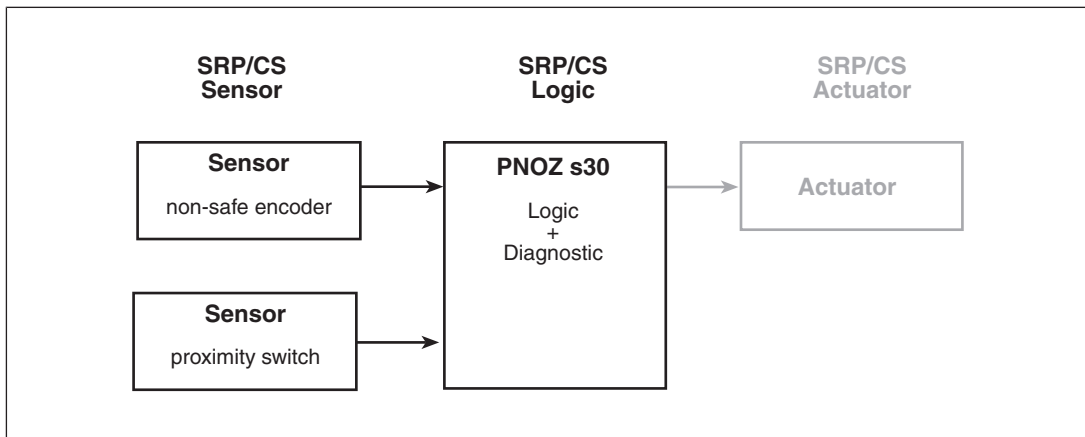

To calculate the safety function you need the following data for the "Sensor" subsystem and "PNOZ s30" subsystem:

Sensor			PNOZ s30 subsystem	
Category	MTTFd	DC	Operating mode	PFH (1/h)
3	Manufacturer-specific	90%	Monitoring 2 encoders	1,73E-09

In a worst case scenario, the sensor subsystem's characteristic value MTTFd is calculated from the inferior (lower) value of the two sensors.

### 13.3.8.3 Achievable safety level

Safety function	PL in accordance with EN ISO 13849-1: 2015	SIL CL in accordance with EN IEC 62061
Direction Position	PL c (Cat.1)	-
Speed Speed range Standstill	PL e (Cat. 3)	3

**Please note:**

For the "sensor" subsystem, a minimum speed must be exceeded within forced dynamisation.

See under [2 encoder diagnostics / broken shearpin monitoring](#) [21].

### 13.3.9 Safety-related characteristic data for operation with 2 proximity switches

#### 13.3.9.1 Permitted encoder types and output signals

##### Non-safety-related rotary encoder

Permitted encoder types:

- ▶ Inductive proximity switches

Permitted output circuits:

- ▶ pnp - N/O contact
- ▶ npn - N/O contact

### 13.3.9.2 Safety-related architecture

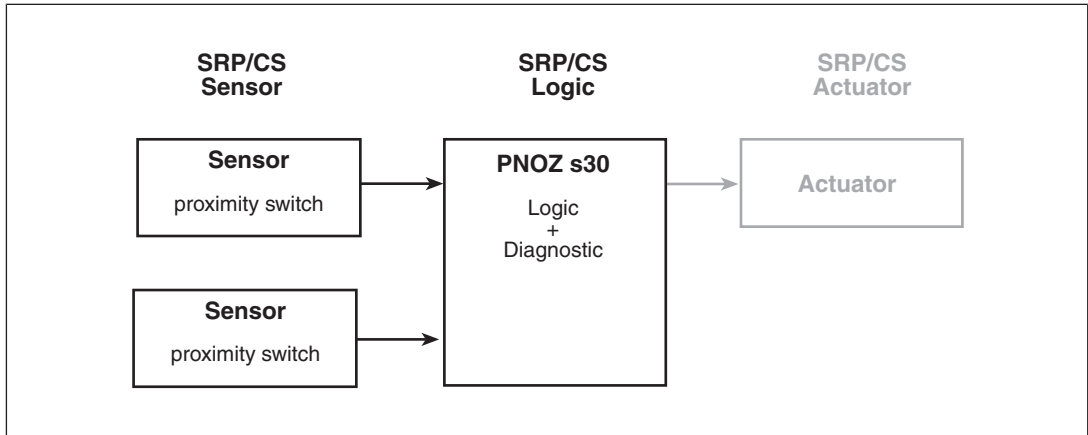

To calculate the safety function you need the following data for the "Sensor" subsystem and "PNOZ s30" subsystem:

Sensor			PNOZ s30 subsystem	
Category	MTTFd	DC	Operating mode	PFH (1/h)
3	Manufacturer-specific	90 % PNP/PNP NPN/NPN	Monitoring 2 encoders	1,73E-09
4		99% PNP/NPN NPN/PNP		

In a worst case scenario, the sensor subsystem's characteristic value MTTFd is calculated from the inferior (lower) value of the two sensors.

### 13.3.9.3 Achievable safety level

Safety function	PL in accordance with EN ISO 13849-1: 2015	SIL CL in accordance with EN IEC 62061
Direction Position	-	-
Speed Speed range Standstill	PL e (Cat.4)	3

Please note:

Common cause failures (CCF) are possible for the sensor subsystem. An appropriate analysis must be carried out.

To use proximity switches 1 and 2 we recommend that you:

- ▶ Use different technologies/design or physical principles (e.g. different manufacturers) and



- ▶ Evaluate the encoder supply via track S

### 13.3.10 Safety characteristic data for operation with 2 proximity switches with reduced diagnostics

#### 13.3.10.1 Permitted encoder types and output signals

##### Non-safety-related rotary encoder

Permitted encoder types:

- ▶ Inductive proximity switches

Permitted output circuits:

- ▶ pnp

#### 13.3.10.2 Safety-related architecture

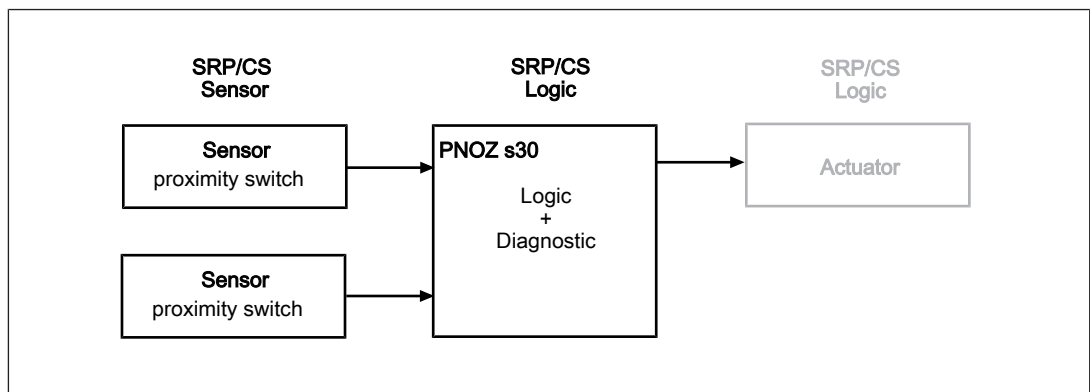

The supply voltage of the proximity switches must be monitored as a measure against systemic failure.

To calculate the safety function you need the following data for the "Sensor" subsystem and "PNOZ s30" subsystem:

Sensor			Subsystem PNOZ s30	
Category	MTTFd	DC	Operating mode	PFH (1/h)
3	Manufacturer-specific	60%	Monitoring 2 encoders	1,73E-09

In a worst case scenario, the sensor subsystem's characteristic value MTTFd is calculated from the inferior (lower) value of the two sensors.

**13.3.10.3 Achievable safety level**

Safety function	PL in accordance with EN ISO 13849-1: 2015	SIL CL in accordance with EN IEC 62061
Direction Position	-	-
Speed Speed range Standstill	PL d (Cat. 3)	2

Please note:

Common cause failures (CCF) are possible for the sensor subsystem. An appropriate analysis must be carried out.

**13.4 Examples****13.4.1 Connection of proximity switch****13.4.1.1 Features****PNOZ s30**

- ▶ Standstill monitoring to enable safety gate via Rel. 1:  
Standstill is detected at  $\leq 2$  Hz, the output Rel. 1 switches on and the safety gate can be unlocked with pushbutton S3.
- ▶ Monitoring for overspeed via Rel. 2:  
Overspeed is detected at  $> 500$  Hz and the output Rel. 2 switches off.
- ▶ Feedback loop monitoring for Rel.1 via feedback loop input Y1,  
Feedback loop monitoring for Rel.2 via feedback loop input Y2
- ▶ Automatic start

**Encoder**

The measured values are detected by two proximity switches (pnp).

**PNOZ s4**

- ▶ Safety gate monitoring

### 13.4.1.2 Configuration overview

language	English	input device								A: pnp / B: pnp		global standstill (10 mHz-1 MHz)	2 Hz	
delay time start-up (0-600s)	Hysteresis (0-50%)	F1	F2	F3	F4	F5	F6	F7	F8	F9	input device settings (10 mHz-1 MHz)			
units	P0	Standstill	500 Hz								f max (A/B)	3000 Hz	f max (Z)	
conversion	P1										ratio (0,0001-400,000:1)			
mode select input	P2										position monitoring (SOS-M)			
Sel 1 (Y10) Sel 2 (Y11) Sel 3 (Y12) Sel 4 (Y13)	P3										reset mode:	monitored (default)	position window width (1-24.900.000 Imp)	
	P4										Pos. 1		Pos. 2	
	P5										Pos. 3		Pos. 4	
	P6										direction monitoring (SDI-M)			
delay time select input (0-30s)	P7										Auto reset:	deactivated (default)	direction tolerance (max. wrong)	
assign outputs (functions) delay time effect (outputs) delay time 0 - 30s (outputs) reset mode Synchronous start output out logic Ausgang Out 4 Analog fmax	P8										direction left		direction right	
	P9										direction right		direction left	
	P10										name of configuration			
	P11										Example 1			
	P12										CRC of configuration			
	P13	Rel. 1 (13/14)	Rel. 2 (23/24)	Ext. 1	Ext. 2	Out 1 (Y32)	Out 2 (Y33)	Out 3 (Y34)	Out 4 (Y35)					
	P14	F1	F2											
	P15	automatic	automatic											
		deactivated	deactivated											

V.15 - CS-TS - T.U.



### 13.4.2 Incremental encoder connection

#### 13.4.2.1 Features PNOZ s30

- ▶ Speed monitoring:
  - Monitoring for overspeed for both operating modes "Setup" and "Automatic", which are selected with the switch S1.
    - The operating mode "Setup" is selected if the select input SEL1 is activated. Overspeed is detected during setup at > 50 Hz and the output Rel. 2 switches off.
    - The operating mode "Automatic" is selected if the select input SEL2 is activated. Overspeed is detected during automatic mode at > 3000 Hz and the output Rel. 2 switches off.
    - If a speed of 2800 Hz is exceeded, the semiconductor output Out1 switches in automatic mode and a message (advance warning) is output via the PLC.
- ▶ Standstill monitoring:
  - Standstill is detected for both operating modes at ≤ 2 Hz and the output Rel. 1 switches on.
- ▶ Feedback loop monitoring via feedback inputs Y1 and Y2

#### Encoder:

The measured values are detected by an incremental encoder (sin/cos)

#### 13.4.2.2 Configuration overview

language	English	input device	Sin/cos 1Vss							global standstill (10 mHz-1 MHz)	2 Hz																																						
delay time start-up (0-600s)	<table border="1" style="width: 100%; border-collapse: collapse;"> <tr><th colspan="2">Hysteresis (0-50%)</th></tr> <tr><td>P0</td><td></td></tr> <tr><td>P1</td><td></td></tr> <tr><td>P2</td><td></td></tr> <tr><td>P3</td><td></td></tr> <tr><td>P4</td><td></td></tr> <tr><td>P5</td><td></td></tr> <tr><td>P6</td><td></td></tr> <tr><td>P7</td><td></td></tr> <tr><td>P8</td><td></td></tr> <tr><td>P9</td><td></td></tr> <tr><td>P10</td><td></td></tr> <tr><td>P11</td><td></td></tr> <tr><td>P12</td><td></td></tr> <tr><td>P13</td><td></td></tr> <tr><td>P14</td><td></td></tr> <tr><td>P15</td><td></td></tr> </table>	Hysteresis (0-50%)		P0		P1		P2		P3		P4		P5		P6		P7		P8		P9		P10		P11		P12		P13		P14		P15		F1	F2	F3	F4	F5	F6	F7	F8	F9	input device settings (10 mHz-1 MHz)	f max (A/B)	20 kHz	f max (Z)	
Hysteresis (0-50%)																																																	
P0																																																	
P1																																																	
P2																																																	
P3																																																	
P4																																																	
P5																																																	
P6																																																	
P7																																																	
P8																																																	
P9																																																	
P10																																																	
P11																																																	
P12																																																	
P13																																																	
P14																																																	
P15																																																	
units	Standstill	50 Hz	50 Hz								ratio (0,0001-400,000:1)																																						
conversion	Standstill	3000 Hz	2000 Hz								position monitoring (SOS-M)																																						
mode select input											reset mode:																																						
Sel 1 (Y10) Sel 2 (Y11) Sel 3 (Y12) Sel 4 (Y13)											position window width (1-24,900,000 Imp)																																						
											Pos. 1																																						
											Pos. 2																																						
											Pos. 3																																						
delay time select input (0-30s)											Pos. 4																																						
20 ms											direction monitoring (SDI-M)																																						
assign outputs (functions)	Rel. 1 (13/14)	Rel. 2 (23/24)									Auto reset:																																						
delay time effect (outputs)	F1	F2									direction tolerance (max. wrong)																																						
delay time 0 - 30s (outputs)											direction left																																						
reset mode	automatic	automatic									max. right																																						
Synchronous start	deactivated	deactivated									direction right																																						
output out logic											max. left																																						
Ausgang Out 4 Analog fmax											name of configuration																																						
											Example 2																																						
											CRC of configuration																																						

V.15 - CS-TS - T.U.

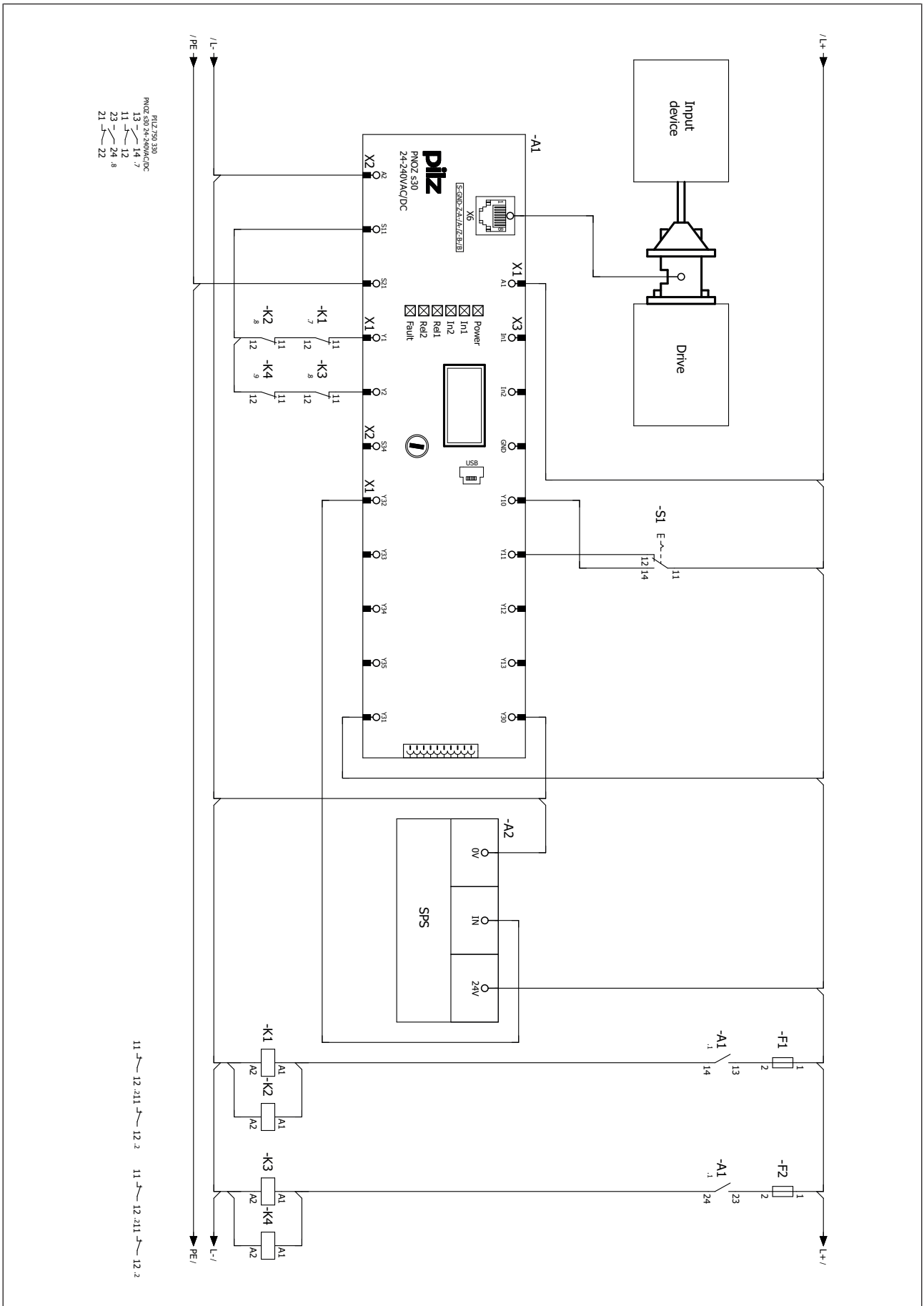

## 14 Order reference

### 14.1 Product

Product type	Features	Terminals	Order no.
PNOZ s30	24 - 240 VAC/DC	With screw terminals	750330
PNOZ s30 C	24 - 240 VAC/DC	With spring-loaded terminals	751330

### 14.2 Accessories

#### Configuration accessories

Product type	Features	Order no.
PNOZsigma Configurator	Software tool for configuration of the PNOZ s30 on the PC	
PNOZsigma configurator s30 Licence unltid	Licence for PNOZsigma Configurator, for configuration of PNOZ s30, no time limit, licence is bound to a workplace.	750700
PNOZsigma configurator s30 Licence 1y.	Licence for PNOZsigma Configurator, for configuration of PNOZ s30, time limited to 1 year, licence is bound to a workplace.	750701
PASkey	USB Crypto memory in robust metallic housing. For secure, convenient storage and transfer of PASunits. Including 8 GB USB 2.0 Flash RAM Drive, industrial quality.	317999
PNOZ s30 USB-configuration-cable	USB cable for transferring the configuration from the PNOZ s30 to the PNOZsigma Configurator and vice versa	750040

#### Chip card accessories

Product type	Features	Order no.
PNOZsigma Chip Card manager set	Set consisting of the PNOZ Chip Card Reader and SmartCardCommander with SIM card adapter (779 230 and 750 031)	750030
SmartCardCommander with SIM card adapter	Software for the chip card reader 779 230, for saving the configuration on the computer	750031
PNOZmulti Chipcard Set	Chip card, 8 kB, x10	779200
PNOZmulti Chipcard	Chip card, 8 kB	779201
PNOZmulti Chipcard	Chip card, 32 kB	779211

Product type	Features	Order no.
PNOZmulti Chipcard Set	Chip card, 32 kB, x10	779212
PNOZ Chip Card Reader	Chip card reader for saving the configuration on the computer	779230
Chipcard Holder	Chip card holder	779240
PNOZmulti Seal	Chip card seal, x10	779250

### Terminals

Product type	Features	Order no.
PNOZ s Set3 Screw Loaded Terminals	Set of plug-in screw terminals, x1	750014
PNOZ s Set3 Spring Loaded Terminals	Set of plug-in spring terminals, x1	751014

### Terminator

Product type	Features	Order no.
PNOZ s terminator plug (10 pieces)	Connector for terminating a PNOZsigma base unit or PNOZsigma expansion module, x10	750010

### Cable

Product type	Features	Order no.
PNOZ msi1Ap	Adapter and cable 25-pin, 2.5 m	773840
PNOZ msi1Ap	Adapter and cable 25-pin, 5.0 m	773844
PNOZ msi1Bp	Adapter and cable 25-pin, 2.5 m	773841
PNOZ msi1Bp	25-pin, 5.0 m	773839
PNOZ msi3Ap	Adapter and cable 15-pin, 2.5 m	773842
PNOZ msi3Bp	Adapter and cable 15-pin, 2.5 m	773843
PNOZ msi5p	Adapter and cable Bos/Rex 15-pin, 2.5 m	773857
PNOZ msi5p	Adapter and cable Bos/Rex 15-pin, 1.5 m	773858
PNOZ msi6p	Adapter and cable Elau 9-pin, 7.5 m	773859
PNOZ msi6p	Adapter and cable Elau 9-pin, 2.5 m	773860
PNOZ msi6p	Adapter and cable Elau 9-pin, 1.5 m	773861
PNOZ msi7p	Adapter and cable SEW 15-pin, 2.5 m	773864
PNOZ msi7p	Adapter and cable SEW 15-pin, 1.5 m	773865
PNOZ msi8p	Adapter and cable Lenze 9-pin, 2.5 m	773862
PNOZ msi8p	Adapter and cable Lenze 9-pin, 1.5 m	773863
PNOZ msi9p	Adapter cable 5.0 m	773856
PNOZ msi10p	Adapter cable 2.5 m	773854
PNOZ msi11p	Adapter cable 1.5 m	773855
PNOZ msi12p	Adapter cable 2.5 m	773868
PNOZ msi13p	Adapter cable 2.5 m	773869



Product type	Features	Order no.
PNOZ msi14p	Adapter cable 2.5 m	773878
PNOZ msi15p	Adapter cable 2.5 m	773874
PNOZ msi16p	Adapter cable 2.5 m	773867
PNOZ msi17p	Adapter cable 5.0 m	773875
PNOZ msi18p	Adapter cable 1.5 m	773888
PNOZ msi19p	Connection cable, 1.5 m	773846
PNOZ msi19p	Connection cable, 2.5 m	773847
PNOZ msi20p	Connection cable, 2.5 m	773879
PNOZ msi21p	Connection cable, 1.5 m	773886
PNOZ msi21p	Connection cable, 2.5 m	773885
PNOZ msi b4 Box	Connection box	773845
PNOZ msi S09	9-pin adapter, connector set	773870
PNOZ msi S15	15-pin adapter, connector set	773871
PNOZ msi S25	25-pin adapter, connector set	773872
PNOZ msi S25	25-pin adapter, connector set	773872
PNOZ s30 USB-configuration-cable	USB cable for transferring the configuration from the PNOZ s30 to the PNOZsigma Configurator and vice versa	750040

#### PNOZsigma expansion modules

Product type	Features	Order no.
PNOZ s7	1 safe relay output	750107
PNOZ s7 C	1 safe relay output	751107
PNOZ s7 C (coated version)	1 safe relay output	751187
PNOZ s7.1	1 safe relay output (+ 1 PNOZ s7, PNOZ s10 or PNOZ s11 can be connected as a contact expansion module)	750167
PNOZ s7.1 C	1 safe relay output (+ 1 PNOZ s7, PNOZ s10 or PNOZ s11 can be connected as a contact expansion module)	751167
PNOZ s7.2	1 safe relay output (+ 1 expansion module PNOZ s7, PNOZ s10 or PNOZ s11 can be connected)	750177
PNOZ s7.2 C	1 safe relay output (+ 1 expansion module PNOZ s7, PNOZ s10 or PNOZ s11 can be connected)	751177
PNOZ s10	1 safe relay output	750110
PNOZ s10 C	1 safe relay output	751110
PNOZ s11	1 safe relay output	750111
PNOZ s11 C	1 safe relay output	751111

<b>Product type</b>	<b>Features</b>	<b>Order no.</b>
PNOZ s22	2 safe relay outputs	750132
PNOZ s22 C	2 safe relay outputs	751132

## 15 **EC declaration of conformity**

This product/these products meet the requirements of the directive 2006/42/EC on machinery of the European Parliament and of the Council. The complete EC Declaration of Conformity is available on the Internet at [www.pilz.com/downloads](http://www.pilz.com/downloads).

Representative: Pilz GmbH & Co. KG, Felix-Wankel-Str. 2, 73760 Ostfildern, Germany

## 16 UKCA-Declaration of Conformity

This product(s) complies with following UK legislation: Supply of Machinery (Safety) Regulation 2008.

The complete UKCA Declaration of Conformity is available on the Internet at [www.pilz.com/downloads](http://www.pilz.com/downloads).

Representative: Pilz Automation Technology, Pilz House, Little Colliers Field, Corby, Northamptonshire, NN18 8TJ United Kingdom, eMail: [mail@pilz.co.uk](mailto:mail@pilz.co.uk)

# Support

Technical support is available from Pilz round the clock.

## Americas

### Brazil

+55 11 97569-2804

### Canada

+1 888 315 7459

### Mexico

+52 55 5572 1300

### USA (toll-free)

+1 877-PILZUSA (745-9872)

## Asia

### China

+86 400-088-3566

### Japan

+81 45 471-2281

### South Korea

+82 31 778 3300

## Australia and Oceania

### Australia

+61 3 95600621

### New Zealand

+64 9 6345350

## Europe

### Austria

+43 1 7986263-444

### Belgium, Luxembourg

+32 9 3217570

### France

+33 3 88104003

### Germany

+49 711 3409-444

### Ireland

+353 21 4804983

### Italy, Malta

+39 0362 1826711

## Scandinavia

+45 74436332

## Spain

+34 938497433

## Switzerland

+41 62 88979-32

## The Netherlands

+31 347 320477

## Turkey

+90 216 5775552

## United Kingdom

+44 1536 462203

## You can reach our international hotline on:

+49 711 3409-222

support@pilz.com

Pilz develops environmentally-friendly products using ecological materials and energy-saving technologies. Offices and production facilities are ecologically designed, environmentally-aware and energy-saving. So Pilz offers sustainability, plus the security of using energy-efficient products and environmentally-friendly solutions.



CECE<sup>®</sup>, CHRE<sup>®</sup>, CMSE<sup>®</sup>, INDUSTRIAL P<sup>®</sup>, Leansafe<sup>®</sup>, Myzei<sup>®</sup>, PAS4000<sup>®</sup>, PASscal<sup>®</sup>, PASconfig<sup>®</sup>, Pilz<sup>®</sup>, PIT<sup>®</sup>, PMSprimo<sup>®</sup>, PMSprotego<sup>®</sup>, PMCiendo<sup>®</sup>, PMD<sup>®</sup>, PME<sup>®</sup>, PNOZ<sup>®</sup>, Primo<sup>®</sup>, PSEN<sup>®</sup>, PSS<sup>®</sup>, PVS<sup>®</sup>, SafetyBUS p<sup>®</sup>, SafetyNET p<sup>®</sup>, THE SPIRIT OF SAFETY<sup>®</sup> are registered and protected trademarks of Pilz GmbH & Co. KG in some countries. We would point out that product features may vary from the details stated in this document, depending on the status at the time of publication and the scope of the equipment. We accept no responsibility for the validity, accuracy and entirety of the text and graphics presented in this information. Please contact our Technical Support if you have any questions.

We are represented internationally. Please refer to our homepage [www.pilz.com](http://www.pilz.com) for further details or contact our headquarters.

Headquarters: Pilz GmbH & Co. KG, Felix-Wankel-Straße 2, 73760 Ostfildern, Germany  
Telephone: +49 711 3409-0, E-Mail: [info@pilz.com](mailto:info@pilz.com), Internet: [www.pilz.com](http://www.pilz.com)

**PILZ**  
THE SPIRIT OF SAFETY